



TABLE OF CONTENTS

1. GENERAL INFORMATION

Quality Control and Assurance	1
Precautions for using Vincenc LED Products	2
Precautions for using Vincenc LED Products	3
Absolute Maximum Ratings	4
Typical Electrical-Optical Characteristics Curves	4

2. SELECTION GUIDE TO CHIP LED LAMPS

1206 Flat Top Type LED	6
1206 with Inner Lens Chip LED	7
Right Angle Lens / 2.0mm Height Chip LED	8
Right Angle Lens / 1.7mm Height Chip LED	9
Right Angle Lens / 1.0mm Height Chip LED	10
0805 Flat Top Chip LED	11
0603 (0.8mm) Chip LED	12
0603 (0.6mm) Chip LED	13
0603 (0.4mm) Chip LED	14
1206 Bi-Color Chip LED	15
Bi-Color Chip LED	16
Right Angle Lens Bi-Color Chip LED	17
0605 Super Thin Bi-Color Chip LED	18
Multi-Color Chip LED	19
Multi-Color Chip LED	20
Multi-Color Chip LED	21
0605 Super Thin Multi-Color Chip LED	22
1206 Resistor Built-in Chip LED	23
1206 Blinking Chip LED	24
Axial LED	25
Axial LED With GULL WING Lead	26
Axial LED With YOKE Lead	27
Axial LED With Z Bent Lead	28
Tape And Reel 1206 Flat Top Chip LED	29
Tape And Reel 1206 With Inner Lens Chip LED	30
Tape And Reel Right Angle Lens / 2.0mm Height Chip LED	31
Tape And Reel Right Angle Lens / 1.7mm Height Chip LED	32
Tape And Reel Right Angle Lens / 1.0mm Height Chip LED	33
Tape And Reel 0805 Flat Top Chip LED	34
Tape And Reel 0603 (0.8mm) Chip LED	35
Tape And Reel 0603 (0.6mm) Chip LED	36
Tape And Reel 0603 (0.4mm) Chip LED	37
Tape And Reel Bi-Color & Multi-Color Chip LED	38
Tape And Reel Right Angle Lens Bi-Color Chip LED	39
Tape And Reel 0605 Super Thin Bi-Color Chip LED	40
Tape And Reel Multi-Color Chip LED	41
Tape And Reel 0605 Super Thin Multi-Color Chip LED	42
Tape And Reel Axial LED With Gull Wing Lead	43
Tape And Reel Axial LED With Yoke Lead	44
Tape And Reel Axial LED With Z Bent Lead	45

3. SELECTION GUIDE TO INFRARED SERIES

Typical Electrical-Optical Characteristics Curves	47
1206 Infrared Emitting Diodes	48
1206 Photo Transistors	49
1206 Photo Diodes	50



GENERAL INFORMATION

QUALITY CONTROL AND ASSURANCE

Classification	Test Item	Reference Standard	Test Conditions	Result
Endurance Test	Operation Life	MIL-STD-750:1026 MIL-STD-883:1005 JIS C 7021 :B-1	Connect with a power $I_f=20\text{mA}$ T_a =Under room temperature Test time=1,000hrs	0/20
	High Temperature High Humidity Storage	MIL-STD-202:103B JIS C 7021 :B-11	$T_a=+65^\circ\text{C}\pm 5^\circ\text{C}$ RH=90%-95% Test time=1,000hrs	0/20
	High Temperature Storage	MIL-STD-883:1008 JIS C 7021 :B-10	High $T_a=+85^\circ\text{C}\pm 5^\circ\text{C}$ Test time=1,000hrs	0/20
	Low Temperature Storage	JIS-C-7021 :B-12	Low $T_a=-35^\circ\text{C}\pm 5^\circ\text{C}$ Test time=1,000hrs	0/20
Environmental Test	Temperature Cycling	MIL-STD-202:107D MIL-STD-750:1051 MIL-STD-883:1010 JIS C 7021 :A-4	$-35^\circ\text{C} \sim +25^\circ\text{C} \sim +85^\circ\text{C} \sim +25^\circ\text{C}$ 60min 20min 60min 20min Test Time=5cycle	0/20
	Thermal Shock	MIL-STD-202:107D MIL-STD-750:1051 MIL-STD-883:1011	$+85^\circ\text{C}\pm 5^\circ\text{C} \sim -35^\circ\text{C}\pm 5^\circ\text{C}$ 20min 20min Test Time=10cycle	0/20
	Solder Resistance	MIL-STD-202:201A MIL-STD-750:2031 JIS C 7021 :A-1	Preheating : $140^\circ\text{C}-160^\circ\text{C}$, within 2 minutes. Operation heating : 235°C (Max.), within 10seconds.(Max.)	0/20

JUDGMENT CRITERIA OF FAILURE FOR THE RELIABILITY

Measuring items	Symbol	Measuring conditions	Judgement criteria for failure
Forward voltage	V_F (V)	$I_f=20\text{mA}$	Over $U_x1.2$
Reverse current	I_r (μA)	$V_r=5\text{V}$	Over U_x2
Luminous intensity	I_v (mcd)	$I_f=20\text{mA}$	Below $S_x0.5$

Note: 1.U means the upper limit of specified characteristics. S means initial value.
 2.Measurement shall be taken between 2 hours and after the test pieces have been returned to normal ambient conditions after completion of each test.



GENERAL INFORMATION

PRECAUTIONS FOR USING VINCENC LED PRODUCTS

1. SOLDERING :

- **Manual Of Soldering**
The temperature of the iron tip should not be higher than 300°C (572°F) and Soldering within 3 seconds per solder-land is to be observed.
- **Reflow Soldering**
Preheating : 140°C~160°C±5°C, within 2 minutes.
Operation heating : 235°C (MAX.) within 10 seconds.(Max)
Gradual Cooling (Avoid quenching).

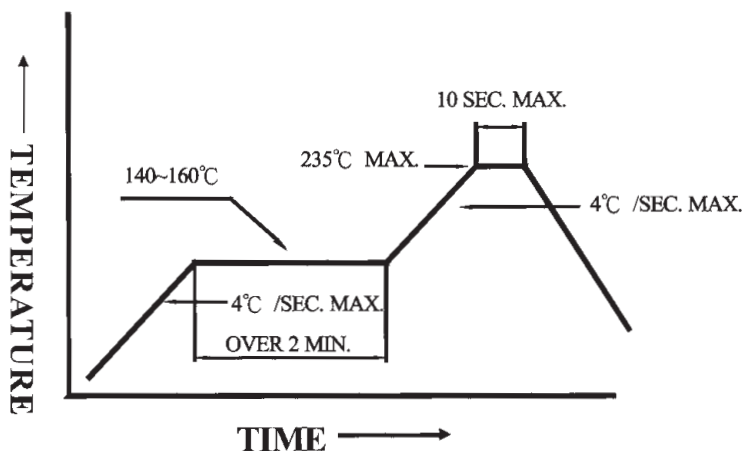

- **DIP soldering (Wave Soldering)**
Preheating : 120°C~150°C, within 120~180 sec.
Operation heating : 245°C±5°C within 5 sec. 260°C (Max)
Gradual Cooling (Avoid quenching).

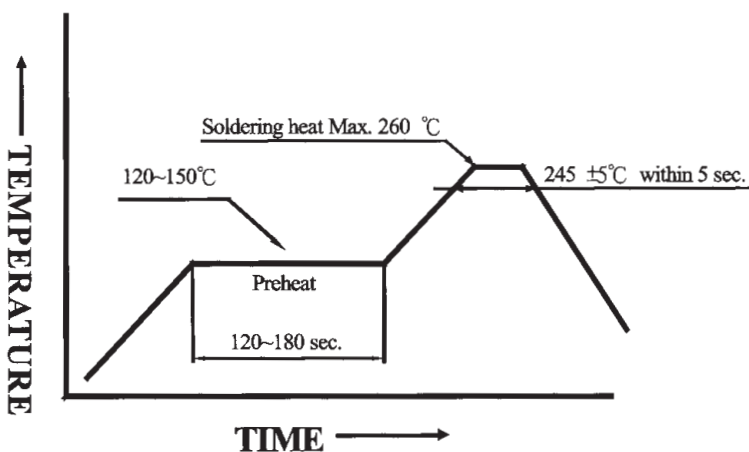

2. Handling :

Care must be taken not to cause to the epoxy resin portion of VINCENC while it is exposed to high temperature.
Care must be taken not rub the epoxy resin portion of VINCENC with hard or sharp article such as the sand blast and the metal hook.



GENERAL INFORMATION

PRECAUTIONS FOR USING VINCENC LED PRODUCTS

3. Notes for designing :

Care must be taken to provide the current limiting resistor in the circuit so as to drive the VINCENC within the rated figures. Also, caution should be taken not to overload VINCENC with instantaneous voltage at the turning ON and OFF of the circuit. When using the pulse drive care must be taken to keep the average current within the rated figures. Also, the circuit should be designed so as to be subjected to reverse voltage when turning off the VINCENC.

4. Storage :

In order to avoid the absorption of moisture, it is recommended to solder VINCENC as soon as possible after unpacking the sealed envelope.

If the envelope is still packed, to store it in the environment as following:

- (1) Temperature : 5°C-30°C (41°F) Humidity : RH 60% Max.
- (2) After this bag is opened, devices that will be applied to infrared reflow, vapor-phase reflow, or equivalent soldering process must be:
 - a. Completed within 24 hours.
 - b. Stored at less than 30% RH.
- (3) Devices require baking before mounting, if:
 - (2) a or (2) b is not met.
- (4) If baking is required, devices must be baked under below conditions:
 - 12 hours at 60°C ± 3°C.

5. Package and Label of Products:

(1) Package: Products are packed in one bag of 3000 pcs (one taping reel) and a label is attached on each bag.

(2) Label:

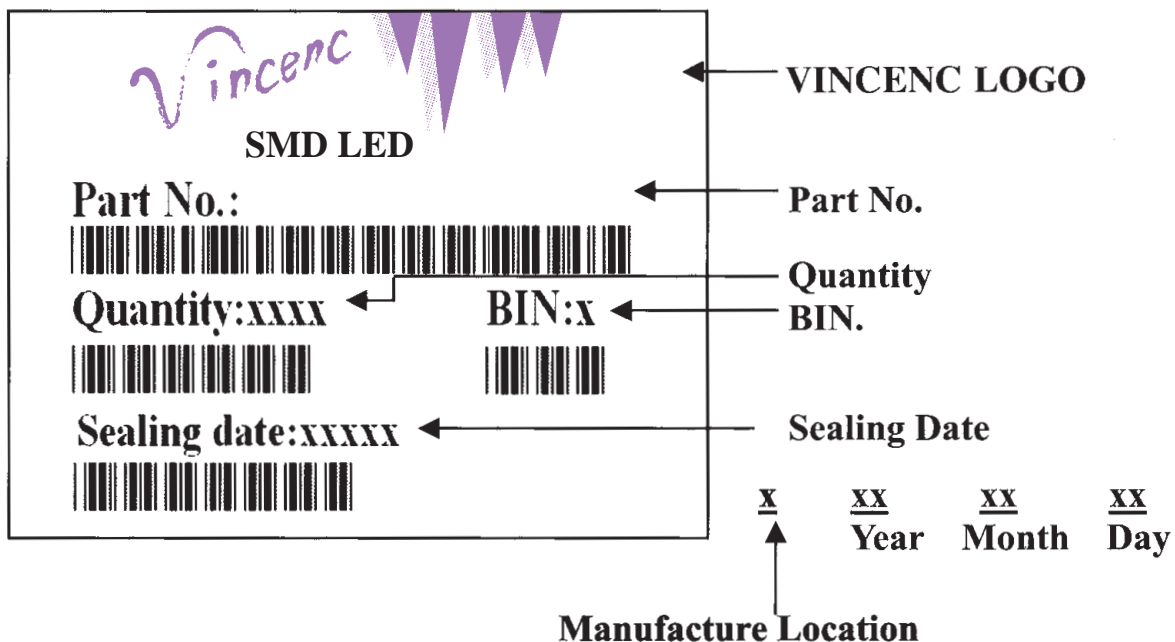

GENERAL INFORMATION

ABSOLUTE MAXIMUM RATINGS

1. Test Condition For Each Parameter :

Parameter	Symbol	Unit	Test Condition
Reverse Voltage	V_R	V	$I_R=100\mu A$
Reverse Current	I_R	μA	$V_R=5V$
Forward Voltage	V_F	V	$I_F=20mA$
Luminous Intensity	I_V	mcd	$I_F=20mA$
Viewing Angle	2θ	Degree	$I_F=20mA$
Spectral Line Half-Width	$\Delta\lambda$	nm	$I_F=20mA$
Power Dissipation	P_D	mw	$I_F=20mA$
Peak Forward Current	I_{FP}	mA	Duty 1/10, Pulse width=0.1ms

2. Absolute Maximum Ratings :

Reverse Voltage	5.0 Volt
Reverse Current($V_R=5V$)	$\leq 100\mu A$
Operating Temperature Range	$-25^\circ C \sim +80^\circ C$
Storage Temperature Range	$-30^\circ C \sim +85^\circ C$

TYPICAL ELECTIEICAL-OPTICAL CHARACTERISTICS CURVES

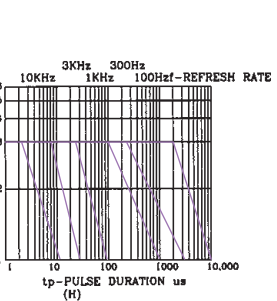
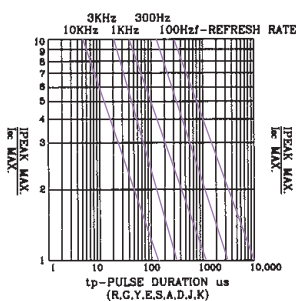
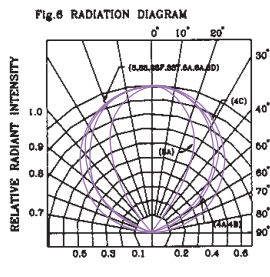
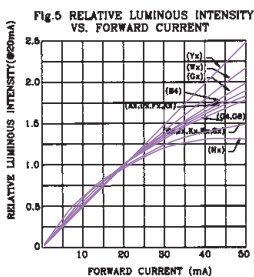
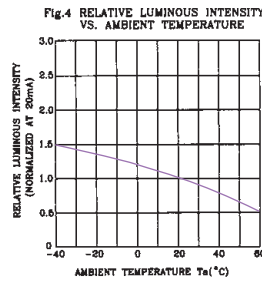
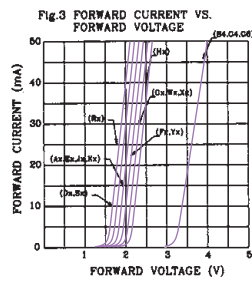
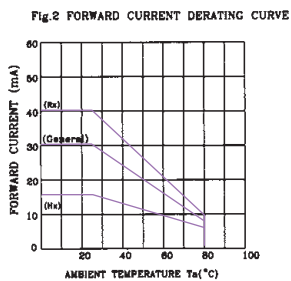
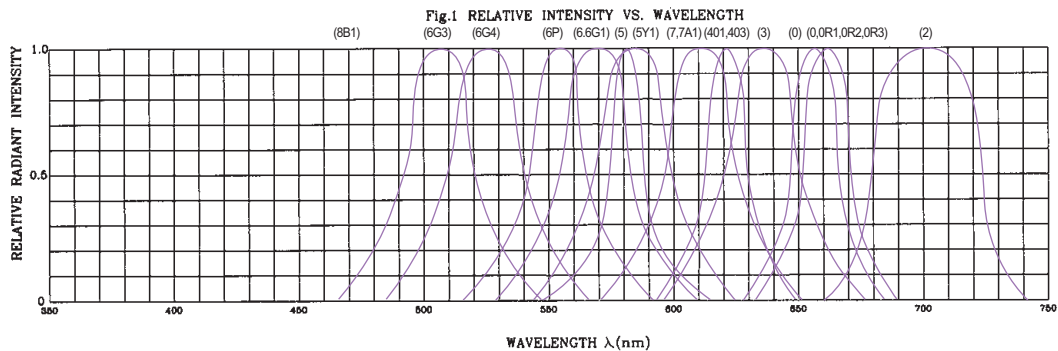



SELECTION GUIDE TO CHIP LED LAMPS

(1) VXX - (2) XX (3) XXX (4) X (5) X - (6) XX



VINCENC HOME DEVELOPMENT CO., LTD.

- | | | |
|---------------------|-----|-------------------------------|
| (1) PRODUCT TYPE | → | (1) SM : Surface Mount Device |
| (2) SIZE | | LL : LED Lamp |
| (3) EMITTING COLOR | (4) | LEAD FRAM |
| (5) LENS APPEARANCE | (6) | DEVELOP ORDER |

(2) SIZE :

1210/ 1206/ 1204 : 15xxx series

0802 : 11xxx series 0805 : 12xxx series 0603 : 10xxx series

(3) EMITTING COLOR :

0 / 0R1 : GaAlAs/GaAs 660nm / Super Red

0R2 : GaAlAs 660nm / Super Red

0R3 : AlGaInP 645nm / Super Red

3 : GaAsP/GaP 640nm / Hi-Eff Red

4O1 / 4O3 : AlGaInP 620nm / Super Orange Red

4O2 : AlGaInP 630nm / Super Orange Red

4F1 : AlGaInP 601nm / Soft Orange

4F2 : AlGaInP 630 / Soft Orange

5 : GaAsP/ GaP 583nm / Yellow

5Y1 / 5Y3 : AlGaInP 590nm / Super Yellow

5Y2 : AlGaInP 595nm / Super Yellow

6 : GaP/GaP 568nm / Yellow Green

6G1 : GaP/GaP 568nm / Hi-Eff Green

6P : GaP/GaP 557nm / Pure Green

6G2 : AlGaInP 570nm / Super Yellow Green

6G3 : InGaN 505nm / Bluish Green

6G4 : InGaN 525nm / Green

6G5 : AlGaInP 525nm / Green

7 : GaAsP/ GaP 610nm / Amber

7A1 : AlGaInP 610nm / Amber

7A2 : AlGaInP 613nm / Amber

8 : AlInGaN 460nm / Super Blue

8B1 : AlInGaN 470nm / Super Blue

(4) LEAD FRAM :

7 : SMD TYPE 0 : AXIAL

(5) LENS APPEARANCE :

1 : Color Diffused 2 : Color Transparent 3 : Water Clear 4: White Diffused

SURFACE MOUNT CHIP LED LAMPS



Absolute Maximum Ratings(Ta=25°C)

	UNIT	SPEC.
IF	mA	30
IFp	mA	100
VR	V	5
Topr	°C	-25~+80
Tstg	°C	-30~+85

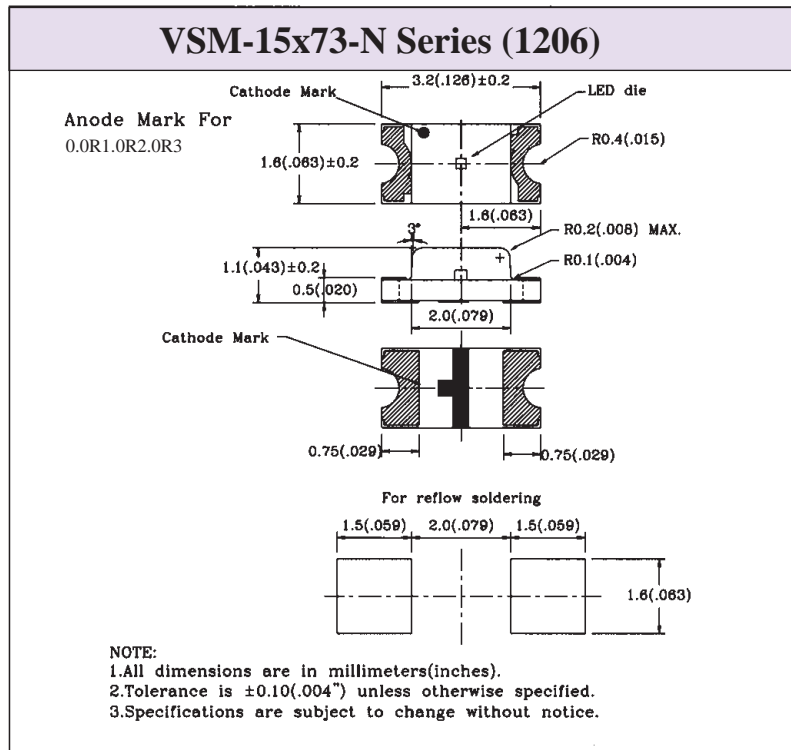

Part No.	Chip				Lens Appearance	Electro-optical Data (At 20mA)				Viewing Angle 2θ 1/2 (deg)
	Material	Emitted Color	λ p (nm)	λ d (nm)		Vf(V)		Iv(mcd)		
						Typ.	Max.	Min.	Typ.	
VSM-15373-N	GaAsP/GaP	Hi-Eff Red	640	628	Water Clear	2.0	2.6	2.4	8.0	120°
VSM-15073-N	GaAlAs/GaAs	Super Red	660	643		1.7	2.6	5.5	15.0	
VSM-150R173-N	GaAlAs/GaAs	Super Red	660	643		1.8	2.6	8.2	25.0	
VSM-150R273-N	GaAlAs	Super Red	660	643		2.1	2.6	18.5	30.0	
VSM-150R373-N	AlGaInP	Super Red	645	632		2.1	2.6	28.0	50.0	
VSM-1540173-N	AlGaInP	Super Orange Red	620	615		2.0	2.6	28.0	50.0	
VSM-1540273-N	AlGaInP	Super Orange Red	630	625		2.1	2.6	28.0	50.0	
VSM-15673-N	GaP/GaP	Yellow Green	568	571		2.1	2.6	3.7	12.0	
VSM-156G173-N	GaP/GaP	Hi-Eff Green	568	570		2.2	2.6	5.5	12.0	
VSM-156P73-N	GaP/GaP	Pure Green	557	563		2.2	2.6	1.6	3.0	
VSM-156G273-N	AlGaInP	Super Yellow Green	570	570		2.0	2.6	18.5	35.0	
VSM-156G373-N	InGaN	Bluish Green	505	505		3.5	4.0	63.0	120.0	
VSM-156G473-N	InGaN	Green	525	525		3.5	4.0	63.0	160.0	
VSM-15573-N	GaAsP/GaP	Yellow	583	585		2.1	2.6	2.4	6.0	
VSM-155Y173-N	AlGaInP	Super Yellow	590	587		2.1	2.6	28.0	45.0	
VSM-155Y273-N	AlGaInP	Super Yellow	595	594		2.1	2.6	28.0	45.0	
VSM-15773-N	GaAsP/GaP	Amber	610	610		2.2	2.6	2.4	5.0	
VSM-157A173-N	AlGaInP	Super Amber	610	605		2.0	2.6	28.0	50.0	

Part No.	Chip				Lens Appearance	Electro-optical Data (At 5mA)				Viewing Angle 2θ 1/2 (deg)
	Material	Emitted Color	λ p (nm)	λ d (nm)		Vf(V)		Iv(mcd)		
						Typ.	Max.	Min.	Typ.	
VSM-15873-N	AlInGaN	Super Blue	460	465-470	Water Clear	2.8	3.2	8.2	15.0	120°
VSM-158B173-N	AlInGaN	Super Blue	470	470-475		2.8	3.2	8.2	20.0	

SURFACE MOUNT CHIP LED LAMPS



Absolute Maximum Ratings(Ta=25°C)

	UNIT	SPEC.
IF	mA	30
IFp	mA	100
VR	V	5
Topr	°C	-25~+80
Tstg	°C	-30~+85

VSM-15x73-Series (1206)

Anode Mark For
0.0R1.0R2.0R3

NOTE:

- 1.All dimensions are in millimeters(inches).
- 2.Tolerance is ±0.10(.004") unless otherwise specified.
- 3.Specifications are subject to change without notice.

Part No.	Chip				Lens Appearance	Electro-optical Data (At 20mA)				Viewing Angle 2θ 1/2 (deg)
	Material	Emitted Color	λ p (nm)	λ d (nm)		Vf(V)		Iv(mcd)		
						Typ.	Max.	Min.	Typ.	
VSM-15373	GaAsP/GaP	Hi-Eff Red	640	628	Water Clear	2.0	2.6	8.2	20.0	60°
VSM-15073	GaAlAs/GaAs	Super Red	660	643		1.7	2.6	12.3	25.0	
VSM-150R173	GaAlAs/GaAs	Super Red	660	643		1.8	2.6	28.0	60.0	
VSM-150R273	GaAlAs	Super Red	660	643		2.1	2.6	42.0	90.0	
VSM-150R373	AlGaInP	Super Red	645	632		2.1	2.6	63.0	100.0	
VSM-154Q173	AlGaInP	Super Orange Red	620	615		2.0	2.6	94.0	160.0	
VSM-154Q273	AlGaInP	Super Orange Red	630	625		2.1	2.6	94.0	160.0	
VSM-15673	GaP/GaP	Yellow Green	568	571		2.1	2.6	12.3	25.0	
VSM-156G173	GaP/GaP	Hi-Eff Green	568	570		2.2	2.6	12.3	40.0	
VSM-156P73	GaP/GaP	Pure Green	557	563		2.2	2.6	3.7	8.0	
VSM-156G273	AlGaInP	Super Yellow Green	570	570		2.0	2.6	42.0	75.0	
VSM-156G373	InGaN	Bluish Green	505	505		3.5	4.0	94.0	150.0	
VSM-156G473	InGaN	Green	525	525		3.5	4.0	140.0	300.0	
VSM-15573	GaAsP/GaP	Yellow	583	585		2.1	2.6	5.5	15.0	
VSM-155Y173	AlGaInP	Super Yellow	590	587		2.1	2.6	63.0	130.0	
VSM-155Y273	AlGaInP	Super Yellow	595	594		2.1	2.6	94.0	200.0	
VSM-15773	GaAsP/GaP	Amber	610	610		2.2	2.6	5.5	12.0	
VSM-157A173	AlGaInP	Super Amber	610	605		2.0	2.6	94.0	160.0	

Part No.	Chip				Lens Appearance	Electro-optical Data (At 5mA)				Viewing Angle 2θ 1/2 (deg)
	Material	Emitted Color	λ p (nm)	λ d (nm)		Vf(V)		Iv(mcd)		
						Typ.	Max.	Min.	Typ.	
VSM-15873	AllnGaN	Super Blue	460	465-470	Water Clear	2.8	3.2	18.5	40.0	60°
VSM-158B173	AllnGaN	Super Blue	470	470-475		2.8	3.2	18.5	45.0	

SURFACE MOUNT CHIP LED LAMPS

VSM-15x73-4A Series (1204)



Anode Mark For
0.0R1.0R2.0R3

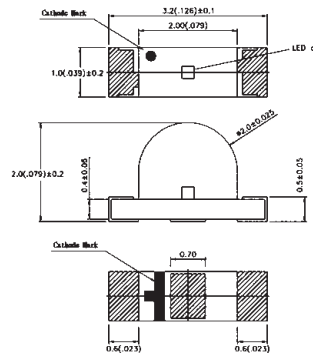

For reflow soldering

For upright mounting

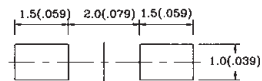

For right enoge mounting

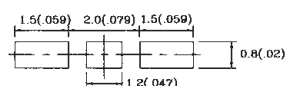

NOTE:

- 1.All dimensions are in millimeters(inches).
- 2.Tolerance is $\pm 0.10(0.004)$ unless otherwise specified.
- 3.Specifications are subject to change without notice.

Absolute Maximum Ratings(Ta=25°C)

	UNIT	SPEC.
IF	mA	30
IFp	mA	100
VR	V	5
Topr	°C	-25~+80
Tstg	°C	-30~+85

Part No.	Chip				Lens Appearance	Electro-optical Data (At 20mA)				Viewing Angle 2θ 1/2 (deg)
	Material	Emitted Color	λ p (nm)	λ d (nm)		Vf(V)		Iv(mcd)		
						Typ.	Max.	Min.	Typ.	
VSM-15373-4A	GaAsP/GaP	Hi-Eff Red	640	628	Water Clear	2.0	2.6	3.7	10.0	100°
VSM-15073-4A	GaAlAs/GaAs	Super Red	660	643		1.7	2.6	8.2	20.0	
VSM-150R173-4A	GaAlAs/GaAs	Super Red	660	643		1.8	2.6	12.3	30.0	
VSM-150R273-4A	GaAlAs	Super Red	660	643		2.1	2.6	12.3	30.0	
VSM-150R373-4A	AlGaInP	Super Red	645	632		2.1	2.6	42.0	70.0	
VSM-154O173-4A	AlGaInP	Super Orange Red	620	615		2.0	2.6	42.0	70.0	
VSM-154O273-4A	AlGaInP	Super Orange Red	630	625		2.1	2.6	42.0	70.0	
VSM-15673-4A	GaP/GaP	Yellow Green	568	571		2.1	2.6	5.5	15.0	
VSM-156G173-4A	GaP/GaP	Hi-Eff Green	568	570		2.2	2.6	8.2	20.0	
VSM-156P73-4A	GaP/GaP	Pure Green	557	563		2.2	2.6	2.4	4.0	
VSM-156G273-4A	AlGaInP	Super Yellow Green	570	570		2.0	2.6	28.0	50.0	
VSM-156G373-4A	InGaN	Bluish Green	505	505		3.5	4.0	63.0	130.0	
VSM-156G473-4A	InGaN	Green	525	525		3.5	4.0	94.0	200.0	
VSM-15573-4A	GaAsP/GaP	Yellow	583	585		2.1	2.6	3.7	10.0	
VSM-155Y173-4A	AlGaInP	Super Yellow	590	587		2.1	2.6	42.0	70.0	
VSM-155Y273-4A	AlGaInP	Super Yellow	595	594		2.1	2.6	42.0	70.0	
VSM-15773-4A	GaAsP/GaP	Amber	610	610		2.2	2.6	2.4	6.0	
VSM-157A173-4A	AlGaInP	Super Amber	610	605		2.0	2.6	42.0	70.0	

Part No.	Chip				Lens Appearance	Electro-optical Data (At 5mA)				Viewing Angle 2θ 1/2 (deg)
	Material	Emitted Color	λ p (nm)	λ d (nm)		Vf(V)		Iv(mcd)		
						Typ.	Max.	Min.	Typ.	
VSM-15873-4A	AlInGaN	Super Blue	460	465-470	Water Clear	2.8	3.2	12.3	25.0	100°
VSM-158B173-4A	AlInGaN	Super Blue	470	470-475		2.8	3.2	12.3	30.0	

SURFACE MOUNT CHIP LED LAMPS

VSM-15x73-4C Series (1204)

Anode Mark For
0.0R1.0R2.0R3

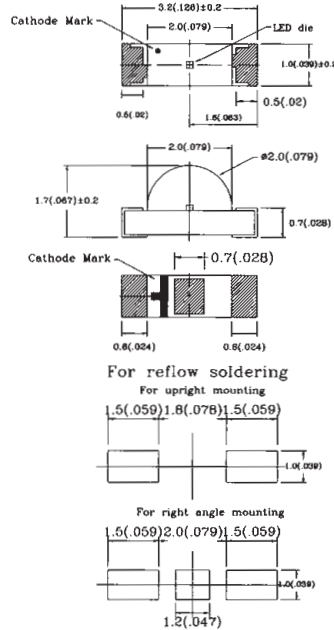
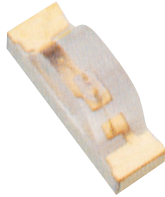

NOTE:

1. All dimensions are in millimeters (inches).
2. Tolerance is ±0.10(.004") unless otherwise specified.
3. Specifications are subject to change without notice.

Absolute Maximum Ratings (Ta=25°C)

	UNIT	SPEC.
IF	mA	30
IFp	mA	100
VR	V	5
Topr	°C	-25~+80
Tstg	°C	-30~+85

Part No.	Chip				Lens Appearance	Electro-optical Data (At 20mA)				Viewing Angle 2θ 1/2 (deg)
	Material	Emitted Color	λ p (nm)	λ d (nm)		Vf(V)		Iv(mcd)		
						Typ.	Max.	Min.	Typ.	
VSM-15373-4C	GaAsP/GaP	Hi-Eff Red	640	628	Water Clear	2.0	2.6	2.4	8.0	105°
VSM-15073-4C	GaAlAs/GaAs	Super Red	660	643		1.7	2.6	8.2	20.0	
VSM-150R173-4C	GaAlAs/GaAs	Super Red	660	643		1.8	2.6	8.2	27.0	
VSM-150R273-4C	GaAlAs	Super Red	660	643		2.1	2.6	12.3	30.0	
VSM-150R373-4C	AlGalnP	Super Red	645	632		2.1	2.6	42.0	70.0	
VSM-154O173-4C	AlGalnP	Super Orange Red	620	615		2.0	2.6	42.0	70.0	
VSM-154O273-4C	AlGalnP	Super Orange Red	630	625		2.1	2.6	42.0	70.0	
VSM-15673-4C	GaP/GaP	Yellow Green	568	571		2.1	2.6	5.5	12.0	
VSM-156G173-4C	GaP/GaP	Hi-Eff Green	568	570		2.2	2.6	8.2	20.0	
VSM-156P73-4C	GaP/GaP	Pure Green	557	563		2.2	2.6	2.4	4.0	
VSM-156G273-4C	AlGalnP	Super Yellow Green	570	570		2.0	2.6	28.0	40.0	
VSM-156G373-4C	InGaN	Bluish Green	505	505		3.5	4.0	63.0	130.0	
VSM-156G473-4C	InGaN	Green	525	525		3.5	4.0	94.0	200.0	
VSM-15573-4C	GaAsP/GaP	Yellow	583	585		2.1	2.6	3.7	10.0	
VSM-155Y173-4C	AlGalnP	Super Yellow	590	587		2.1	2.6	42.0	70.0	
VSM-155Y273-4C	AlGalnP	Super Yellow	595	594		2.1	2.6	42.0	70.0	
VSM-15773-4C	GaAsP/GaP	Amber	610	610		2.2	2.6	2.4	6.0	
VSM-157A173-4C	AlGalnP	Super Amber	610	605		2.0	2.6	42.0	70.0	

Part No.	Chip				Lens Appearance	Electro-optical Data (At 5mA)				Viewing Angle 2θ 1/2 (deg)
	Material	Emitted Color	λ p (nm)	λ d (nm)		Vf(V)		Iv(mcd)		
						Typ.	Max.	Min.	Typ.	
VSM-15873-4C	AlInGaN	Super Blue	460	465-470	Water Clear	2.8	3.2	12.3	25.0	105°
VSM-158B173-4C	AlInGaN	Super Blue	470	470-475		2.8	3.2	12.3	30.0	

SURFACE MOUNT CHIP LED LAMPS



Absolute Maximum Ratings(Ta=25°C)

	UNIT	SPEC.
IF	mA	30
IFp	mA	100
VR	V	5
Topr	°C	-25~+80
Tstg	°C	-30~+85

VSM-11x73 Series (0802)

Anode Mark For
0.0R1.0R2.0R3

NOTE:
1.All dimensions are in millimeters(inches).
2.Tolerance is ±0.10(.004") unless otherwise specified.
3.Specifications are subject to change without notice.

Part No.	Chip				Lens Appearance	Electro-optical Data (At 20mA)				Viewing Angle 2θ 1/2 (deg)
	Material	Emitted Color	λ p (nm)	λ d (nm)		Vf(V)		Iv(mcd)		
						Typ.	Max.	Min.	Typ.	
VSM-11373	GaAsP/GaP	Hi-Eff Red	640	628	Water Clear	2.0	2.6	2.4	6.0	130°
VSM-11073	GaAlAs/GaAs	Super Red	660	643		1.7	2.6	5.5	10.0	
VSM-110R173	GaAlAs/GaAs	Super Red	660	643		1.8	2.6	5.5	12.0	
VSM-110R273	GaAlAs	Super Red	660	643		2.1	2.6	12.3	20.0	
VSM-110R373	AlGaInP	Super Red	645	632		2.1	2.6	28.0	40.0	
VSM-1140173	AlGaInP	Super Orange Red	620	615		2.0	2.6	28.0	40.0	
VSM-1140273	AlGaInP	Super Orange Red	630	625		2.1	2.6	28.0	40.0	
VSM-11673	GaP/GaP	Yellow Green	568	571		2.1	2.6	2.4	5.0	
VSM-116G173	GaP/GaP	Hi-Eff Green	568	570		2.2	2.6	3.7	10.0	
VSM-116P73	GaP/GaP	Pure Green	557	563		2.2	2.6	1.0	2.0	
VSM-116G273	AlGaInP	Super Yellow Green	570	570		2.0	2.6	12.3	25.0	
VSM-116G373	InGaN	Bluish Green	505	505		3.5	4.0	63.0	1000	
VSM-116G473	InGaN	Green	525	525		3.5	4.0	63.0	15.0	
VSM-11573	GaAsP/GaP	Yellow	583	585		2.1	2.6	1.6	4.0	
VSM-115Y173	AlGaInP	Super Yellow	590	587		2.1	2.6	28.0	40.0	
VSM-115Y273	AlGaInP	Super Yellow	595	594		2.1	2.6	28.0	40.0	
VSM-11773	GaAsP/GaP	Amber	610	610		2.2	2.6	1.6	4.0	
VSM-117A173	AlGaInP	Super Amber	610	605		2.0	2.6	28.0	40.0	

Part No.	Chip				Lens Appearance	Electro-optical Data (At 5mA)				Viewing Angle 2θ 1/2 (deg)
	Material	Emitted Color	λ p (nm)	λ d (nm)		Vf(V)		Iv(mcd)		
						Typ.	Max.	Min.	Typ.	
VSM-11873	AllnGaN	Super Blue	460	465-470	Water Clear	2.8	3.2	5.5	10.0	130°
VSM-118B173	AllnGaN	Super Blue	470	470-475		2.8	3.2	5.5	15.0	

SURFACE MOUNT CHIP LED LAMPS



Absolute Maximum Ratings(Ta=25°C)

	UNIT	SPEC.
IF	mA	30
IFp	mA	100
VR	V	5
Topr	°C	-25~+80
Tstg	°C	-30~+85

VSM-12x73 Series (0805)

Anode Mark For
0.0R1.0R2.0R3

NOTE:

- 1.All dimensions are in millimeters(inches).
- 2.Tolerance is ±0.10(.004") unless otherwise specified.
- 3.Specifications are subject to change without notice.

Part No.	Chip				Lens Appearance	Electro-optical Data (At 20mA)				Viewing Angle 2θ 1/2 (deg)
	Material	Emitted Color	λ p (nm)	λ d (nm)		Vf(V)		Iv(mcd)		
						Typ.	Max.	Min.	Typ.	
VSM-12373	GaAsP/GaP	Hi-Eff Red	640	628	Water Clear	2.0	2.6	2.4	8.0	120°
VSM-12073	GaAlAs/GaAs	Super Red	660	643		1.7	2.6	5.5	15.0	
VSM-120R173	GaAlAs/GaAs	Super Red	660	643		1.8	2.6	8.2	25.0	
VSM-120R273	GaAlAs	Super Red	660	643		2.1	2.6	18.5	30.0	
VSM-120R373	AlGaInP	Super Red	645	632		2.1	2.6	28.0	50.0	
VSM-124O173	AlGaInP	Super Orange Red	620	615		2.0	2.6	28.0	50.0	
VSM-124O273	AlGaInP	Super Orange Red	630	625		2.1	2.6	28.0	50.0	
VSM-12673	GaP/GaP	Yellow Green	568	571		2.1	2.6	3.7	12.0	
VSM-126G173	GaP/GaP	Hi-Eff Green	568	570		2.2	2.6	5.5	12.0	
VSM-126P73	GaP/GaP	Pure Green	557	563		2.2	2.6	1.6	3.0	
VSM-126G273	AlGaInP	Super Yellow Green	570	570		2.0	2.6	18.5	35.0	
VSM-126G373	InGaN	Bluish Green	505	505		3.5	4.0	63.0	120.0	
VSM-126G473	InGaN	Green	525	525		3.5	4.0	63.0	160.0	
VSM-12573	GaAsP/GaP	Yellow	583	585		2.1	2.6	2.4	6.0	
VSM-125Y173	AlGaInP	Super Yellow	590	587		2.1	2.6	28.0	45.0	
VSM-125Y273	AlGaInP	Super Yellow	595	594		2.1	2.6	28.0	45.0	
VSM-12773	GaAsP/GaP	Amber	610	610		2.2	2.6	2.4	5.0	
VSM-127A173	AlGaInP	Super Amber	610	605		2.0	2.6	28.0	50.0	

Part No.	Chip				Lens Appearance	Electro-optical Data (At 5mA)				Viewing Angle 2θ 1/2 (deg)
	Material	Emitted Color	λ p (nm)	λ d (nm)		Vf(V)		Iv(mcd)		
						Typ.	Max.	Min.	Typ.	
VSM-12873	AlInGaN	Super Blue	460	465-470	Water Clear	2.8	3.2	8.2	15.0	120°
VSM-128B173	AlInGaN	Super Blue	470	470-475		2.8	3.2	8.2	20.0	

SURFACE MOUNT CHIP LED LAMPS



Absolute Maximum Ratings(Ta=25°C)

	UNIT	SPEC.
IF	mA	30
IFp	mA	100
VR	V	5
Topr	°C	-25~+80
Tstg	°C	-30~+85

VSM-10x73-6D Series (0603-0.8mm)

Anode Mark For
0.0R1.0R2.0R3

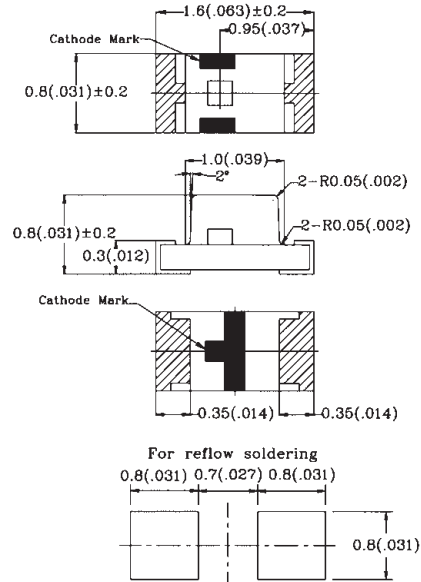

NOTE:

- 1.All dimensions are in millimeters(inches).
- 2.Tolerance is $\pm 0.10(.004)$ unless otherwise specified.
- 3.Specifications are subject to change without notice.

Part No.	Chip				Lens Appearance	Electro-optical Data (At 20mA)				Viewing Angle 2θ 1/2 (deg)
	Material	Emitted Color	λ p (nm)	λ d (nm)		Vf(V)		Iv(mcd)		
						Typ.	Max.	Min.	Typ.	
VSM-10373-6D	GaAsP/GaP	Hi-Eff Red	640	628	Water Clear	2.0	2.6	2.4	8.0	120°
VSM-10073-6D	GaAlAs/GaAs	Super Red	660	643		1.7	2.6	5.5	15.0	
VSM-100R173-6D	GaAlAs/GaAs	Super Red	660	643		1.8	2.6	8.2	25.0	
VSM-100R273-6D	GaAlAs	Super Red	660	643		2.1	2.6	18.5	30.0	
VSM-100R373-6D	AlGaInP	Super Red	645	632		2.1	2.6	28.0	50.0	
VSM-104Q173-6D	AlGaInP	Super Orange Red	620	615		2.0	2.6	28.0	50.0	
VSM-104Q273-6D	AlGaInP	Super Orange Red	630	625		2.1	2.6	28.0	50.0	
VSM-10673-6D	GaP/GaP	Yellow Green	568	571		2.1	2.6	3.7	12.0	
VSM-106G173-6D	GaP/GaP	Hi-Eff Green	568	570		2.2	2.6	5.5	12.0	
VSM-106P73-6D	GaP/GaP	Pure Green	557	563		2.2	2.6	1.6	3.0	
VSM-106G273-6D	AlGaInP	Super Yellow Green	570	570		2.0	2.6	18.5	35.0	
VSM-106G373-6D	InGaN	Bluish Green	505	505		3.5	4.0	63.0	120.0	
VSM-106G473-6D	InGaN	Green	525	525		3.5	4.0	63.0	160.0	
VSM-10573-6D	GaAsP/GaP	Yellow	583	585		2.1	2.6	2.4	6.0	
VSM-105Y173-6D	AlGaInP	Super Yellow	590	587		2.1	2.6	28.0	45.0	
VSM-105Y273-6D	AlGaInP	Super Yellow	595	594		2.1	2.6	28.0	45.0	
VSM-10773-6D	GaAsP/GaP	Amber	610	610		2.2	2.6	2.4	5.0	
VSM-107A173-6D	AlGaInP	Super Amber	610	605		2.0	2.6	28.0	50.0	

Part No.	Chip				Lens Appearance	Electro-optical Data (At 5mA)				Viewing Angle 2θ 1/2 (deg)
	Material	Emitted Color	λ p (nm)	λ d (nm)		Vf(V)		Iv(mcd)		
						Typ.	Max.	Min.	Typ.	
VSM-10873-6D	AlInGaN	Super Blue	460	465-470	Water Clear	2.8	3.2	8.2	15.0	120°
VSM-108B173-6D	AlInGaN	Super Blue	470	470-475		2.8	3.2	8.2	20.0	

SURFACE MOUNT CHIP LED LAMPS

VSM-10x73-6A Series (0603-0.6mm)

Anode Mark For
0.0R1.0R2.0R3

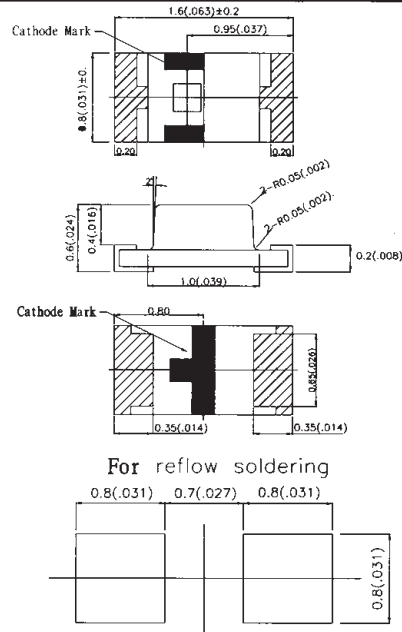

NOTE:

- 1.All dimensions are in millimeters(inches).
- 2.Tolerance is $\pm 0.10(.004)$ unless otherwise specified.
- 3.Specifications are subject to change without notice.

Absolute Maximum Ratings(Ta=25°C)

	UNIT	SPEC.
IF	mA	30
IFp	mA	100
VR	V	5
Topr	°C	-25~+80
Tstg	°C	-30~+85

Part No.	Chip				Lens Appearance	Electro-optical Data (At 20mA)				Viewing Angle 2θ 1/2 (deg)
	Material	Emitted Color	λ p (nm)	λ d (nm)		Vf(V)		Iv(mcd)		
						Typ.	Max.	Min.	Typ.	
VSM-107A273-6A	A1GaInP	Super Amber	613	605	Water Clear	2.0	2.6	63.0	100.0	120°
VSM-104O273-6A	A1GaInP	Super Orange Red	630	625		2.1	2.6	28.0	50.0	
VSM-104O173-6A	A1GaInP	Super Orange Red	620	615		2.0	2.6	28.0	50.0	
VSM-104O373-6A	A1GaInP	Super Orange Red	630	620		2.0	2.6	63.0	100.0	
VSM-107A173-6A	A1GaInP	Super Amber	610	605		2.0	2.6	28.0	50.0	
VSM-105Y373-6A	A1GaInP	Super Yellow	590	587		2.2	2.3	63.0	150.0	
VSM-105Y173-6A	A1GaInP	Super Yellow	590	587		2.1	2.6	28.0	45.0	
VSM-105Y273-6A	A1GaInP	Super Yellow	595	594		2.1	2.6	28.0	45.0	
VSM-106G273-6A	A1GaInP	Super Yellow Green	570	570		2.0	2.6	28.0	50.0	
VSM-10673-6A	A1GaInP	Yellow Green	572	572		2.0	2.6	18.5	35.0	
VSM-106G373-6A	InGaN	Bluish Green	505	505		3.5	4.0	63.0	120.0	
VSM-106G473-6A	InGaN	Green	525	525		3.5	4.0	63.0	160.0	

Part No.	Chip				Lens Appearance	Electro-optical Data (At 5mA)				Viewing Angle 2θ 1/2 (deg)
	Material	Emitted Color	λ p (nm)	λ d (nm)		Vf(V)		Iv(mcd)		
						Typ.	Max.	Min.	Typ.	
VSM-10873-6A	AlInGaN	Super Blue	460	465-470	Water Clear	2.8	3.2	8.2	15.0	120°
VSM-108B173-6A	AlInGaN	Super Blue	470	470-475		2.8	3.2	8.2	20.0	

SURFACE MOUNT CHIP LED LAMPS

VSM-10x73-6G Series (0603-0.4mm)



Anode Mark For
0.0R1.0R2.0R3

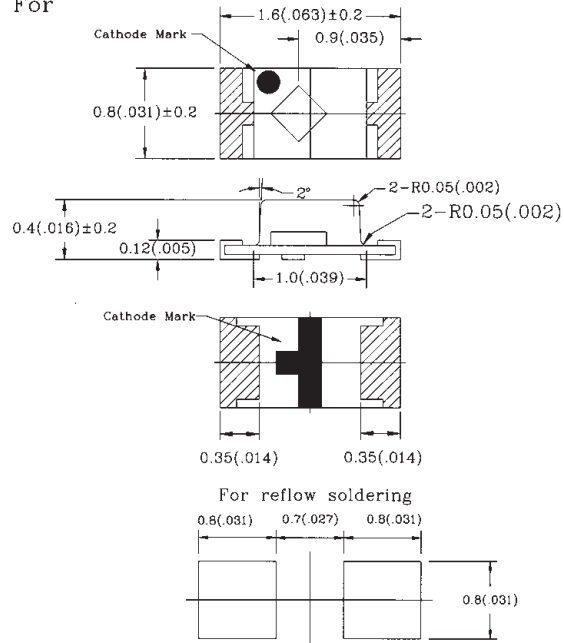

Absolute Maximum Ratings(Ta=25°C)

	UNIT	SPEC.
IF	mA	30
IFp	mA	100
VR	V	5
Topr	°C	-25~+80
Tstg	°C	-30~+85

NOTE:

- 1.All dimensions are in millimeters(inches).
- 2.Tolerance is $\pm 0.10(.004)$ unless otherwise specified.
- 3.Specifications are subject to change without notice.

Part No.	Chip				Lens Appearance	Electro-optical Data (At 20mA)				Viewing Angle $2\theta_{1/2}$ (deg)
	Material	Emitted Color	λ_p (nm)	λ_d (nm)		Vf(V)		Iv(mcd)		
						Typ.	Max.	Min.	Typ.	
VSM-106G273-6G	A1GaInP	Super Yellow Green	570	570	Water Clear	2.0	2.6	18.5	35.0	120°
VSM-106G573-6G	A1GaInP	Green	525	525		3.5	4.0	63.0	160.0	
VSM-106G373-6G	InGaN	Bluish Green	505	505		3.5	4.0	63.0	120.0	
VSM-106G473-6G	InGaN	Green	525	525		3.5	4.0	63.0	160.0	
VSM-107A173-6G	A1GaInP	Super Amber	610	605		2.0	2.6	63.0	100.0	
VSM-104O373-6G	A1GaInP	Super Orange Red	630	620		2.0	2.6	63.0	100.0	
VSM-105Y173-6G	A1GaInP	Super Yellow	590	589		2.0	2.6	63.0	120.0	
VSM-100R373-6G	A1GaInP	Super Red	645	632		2.1	2.6	28.0	50.0	

Part No.	Chip				Lens Appearance	Electro-optical Data (At 5mA)				Viewing Angle $2\theta_{1/2}$ (deg)
	Material	Emitted Color	λ_p (nm)	λ_d (nm)		Vf(V)		Iv(mcd)		
						Typ.	Max.	Min.	Typ.	
VSM-10873-6G	AlInGaN	Super Blue	460	465-470	Water Clear	2.8	3.2	8.2	15.0	120°
VSM-108B173-6G	AlInGaN	Super Blue	470	470-475		2.8	3.2	8.2	20.0	

SURFACE MOUNT DUAL COLOR LED

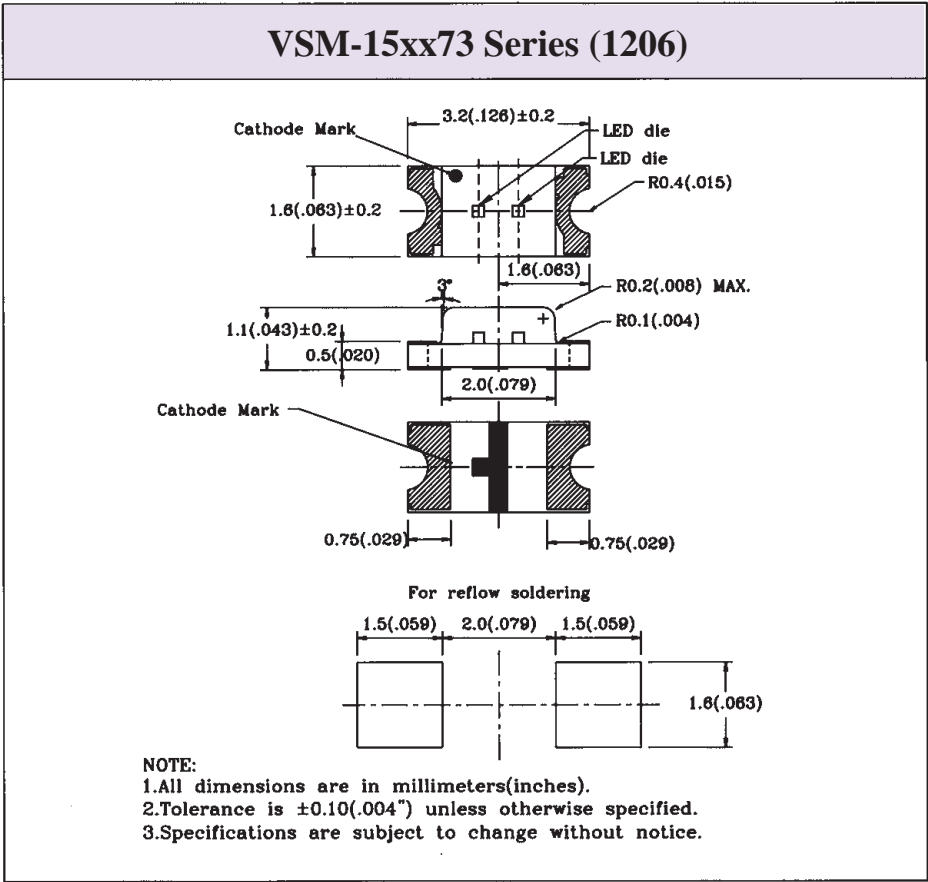
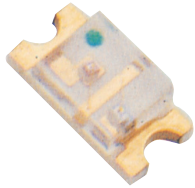

Absolute Maximum Ratings(Ta=25°C)

	UNIT	SPEC.
IF	mA	30
IFp	mA	100
V _k	V	5
Topr	°C	-25~+80
Tstg	°C	-30~+85

Part No.	Chip				Lens Appearance	Electro-optical Data (At 20mA)				Viewing Angle 2θ 1/2 (deg)
	Material	Emitted Color	λ p (nm)	λ d (nm)		V _f (V)		I _v (mcd)		
						Typ.	Max.	Min.	Typ.	
VSM-1506G173	GaAlAs/GaAs	Super Red	660	643	Water Clear	1.8	2.6	12.3	25.0	120°
	GaP/GaP	Hi-Eff Green	568	570		2.2	2.6	5.5	12.0	
VSM-153673	GaAsP/GaP	Hi-Eff Red	640	628		2.0	2.6	5.5	12.0	
	GaP/GaP	Green	568	571		2.2	2.6	2.4	10.0	
VSM-153573	GaAsP/GaP	Hi-Eff Red	640	628		2.0	2.6	5.5	12.0	
	GaAsP/GaP	Yellow	583	585		2.1	2.6	2.4	10.0	
VSM-1536P73	GaAsP/GaP	Hi-Eff Red	640	628		2.0	2.6	5.5	12.0	
	GaP/GaP	Pure Green	557	563		2.2	2.6	0.5	3.0	
VSM-1578B173	GaAsP/GaP	Amber	610	606		2.1	2.6	2.4	8.0	
	AlInGaN	Super Blue	470	470		3.5	4.0	28.0	40.0	
VSM-156573	GaP/GaP	Green	568	571		2.2	2.6	2.4	10.0	
	GaAsP/GaP	Yellow	583	585		2.1	2.6	2.4	10.0	

SURFACE MOUNT DUAL COLOR LED LAMPS

VSM-15xx73-3B Series (1210)

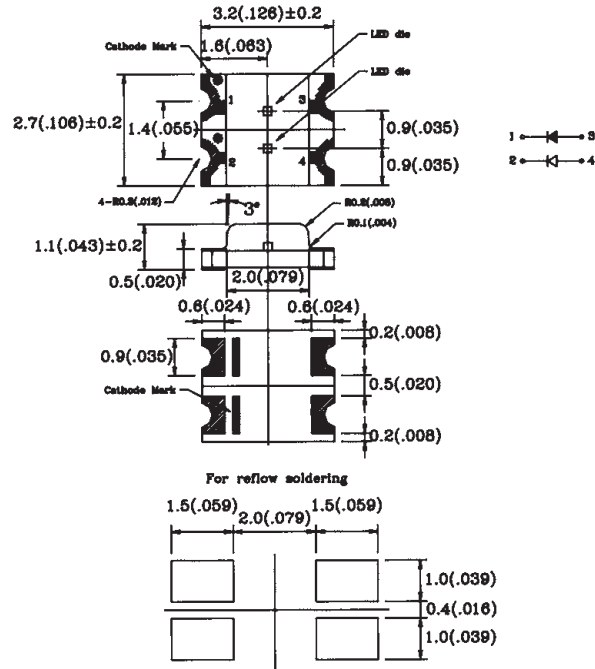
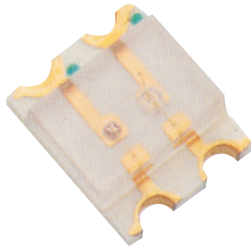

Absolute Maximum Ratings ($T_a = 25^\circ\text{C}$)

	UNIT	SPEC.
IF	mA	30
IFp	mA	100
VR	V	5
Topr	$^\circ\text{C}$	-25~+80
Tstg	$^\circ\text{C}$	-30~+85

Part No.	Chip				Lens Appearance	Electro-optical Data (At 20mA)				Viewing Angle 2θ 1/2 (deg)
	Material	Emitted Color	λ_p (nm)	λ_d (nm)		Vf(V)		Iv(mcd)		
						Typ.	Max.	Min.	Typ.	
VSM-1506G173-3B	GaAlAs/GaAs	Super Red	660	643	Water Clear	1.8	2.6	12.3	25.0	120°
	GaP/GaP	Hi-Eff Green	568	570		2.2	2.6	5.5	12.0	
VSM-1536P73-3B	GaAsP/GaP	Hi-Eff Red	640	628		2.0	2.6	5.5	12.0	
	GaP/GaP	Green	568	571		2.2	2.6	2.4	10.0	
VSM-1535P73-3B	GaAsP/GaP	Hi-Eff Red	640	628		2.0	2.6	5.5	12.0	
	GaAsP/GaP	Yellow	583	585		2.1	2.6	2.4	10.0	
VSM-1536P73-3B	GaAsP/GaP	Hi-Eff Red	640	628		2.0	2.6	5.5	12.0	
	GaP/GaP	Pure Green	557	563		2.2	2.6	0.5	3.0	
VSM-1536G173-3B	GaAsP/GaP	Hi-Eff Red	640	628		2.0	2.6	5.5	12.0	
	GaP/GaP	Hi-Eff Green	568	570		2.2	2.6	5.5	12.0	
VSM-1565P73-3B	GaP/GaP	Green	568	571		2.2	2.6	2.4	10.0	
	GaAsP/GaP	Yellow	583	585		2.1	2.6	2.4	10.0	

SURFACE MOUNT DUAL COLOR LED LAMPS



VSM-15xx73-4B (1204)

For reflow soldering

For upright mounting

For right anode mounting

Cathode Mark

Cathode

NOTE:

1. All dimensions are in millimeters (inches).
2. Tolerance is ±0.10(.004") unless otherwise specified.
3. Specifications are subject to change without notice.

1 Absolute Maximum Ratings (Ta=25°C)

	UNIT	SPEC.
IF	mA	30
IFp	mA	100
V _r	V	5
Topr	°C	-25~+80
Tstg	°C	-30~+85

Part No.	Chip				Lens Appearance	Electro-optical Data (At 20mA)				Viewing Angle 2θ 1/2 (deg)
	Material	Emitted Color	λ _p (nm)	λ _d (nm)		Vf(V)		Iv(mcd)		
						Typ.	Max.	Min.	Typ.	
VSM-158B15Y173-4B	AlInGaN	Super Blue	470	470	Water Clear	3.5	4.0	42.0	70.0	100°
	AlGaInP	Super Yellow	590	587		2.1	2.6	42.0	70.0	
VSM-158B17A173-4B	AlInGaN	Super Blue	470	470		3.5	4.0	42.0	70.0	
	AlGaInP	Super Amber	610	605		2.0	2.6	42.0	70.0	
VSM-157A16G273-4B	AlGaInP	Super Amber	610	605		2.0	2.6	42.0	70.0	
	AlGaInP	Super Yellow Green	570	570		2.0	2.6	28.0	45.0	
VSM-1506G173-4B	GaAlAs/GaAs	Super Red	660	643		1.8	2.6	8.2	25.0	
	GaP/GaP	Hi-Eff Green	568	570		2.2	2.6	5.5	20.0	
VSM-153673-4B	GaAsP/GaP	Hi-Eff Red	640	628		2.0	2.6	5.5	15.0	
	GaP/GaP	Yellow Green	568	571		2.2	2.6	3.7	12.0	
VSM-153573-4B	GaAsP/GaP	Hi-Eff Red	640	628		2.0	2.6	5.5	15.0	
	GaAsP/GaP	Yellow	583	585		2.1	2.6	3.7	12.0	

SURFACE MOUNT DUAL COLOR LED LAMPS

VSM-10xx73-6H Series (0605)

Anode Mark For
0.0R1.0R2.0R3

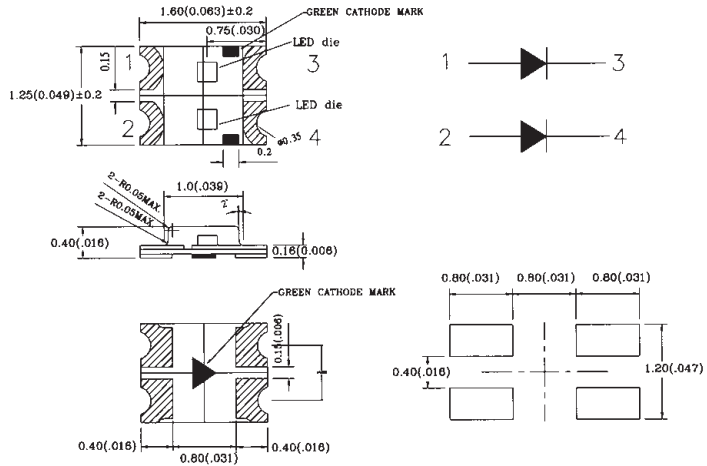

Absolute Maximum Ratings(Ta=25°C)

	UNIT	SPEC.
IF	mA	30
IFp	mA	100
V _R	V	5
Topr	°C	-25~+80
Tstg	°C	-30~+85

- NOTE:
- 1.All dimensions are in millimeters(inches).
 - 2.Tolerance is $\pm 0.10(.004)$ unless otherwise specified.
 - 3.Specifications are subject to change without notice.

Part No.	Chip				Lens Appearance	Electro-optical Data (At 5mA)				Viewing Angle 2θ 1/2 (deg)
	Material	Emitted Color	λ p (nm)	λ d (nm)		Vf(V)		Iv(mcd)		
						Typ.	Max.	Min.	Typ.	
VSM-106G24O273-6H	A1GaInP	Super Yellow Green	570	570	Water Clear	1.8	2.4	3.7	8.0	120°
	A1GaInP	Super Orange Red	630	620		1.8	2.4	8.2	25.0	
VSM-106G20R373-6H	A1GaInP	Super Yellow Green	570	570		1.8	2.4	3.7	8.0	
	A1GaInP	Super Red	645	632		1.8	2.4	5.5	12.0	
VSM-106G25Y173-6H	A1GaInP	Super Yellow Green	570	570		1.8	2.4	3.7	8.0	
	A1GaInP	Super Yellow	590	589		1.8	2.4	12.3	25.0	
VSM-108B17A173-6H	AlInGaN	Super Blue	470	470-475		2.8	3.2	8.2	20.0	
	A1GaInP	Super Amber	610	605		1.8	2.4	12.3	25.0	
VSM-108B16G273-6H	AlInGaN	Super Blue	470	470-475		2.8	3.2	8.2	20.0	
	A1GaInP	Super Yellow Grren	570	570		1.8	2.4	3.7	8.0	
VSM-100R35Y173-6H	A1GaInP	Super Red	645	632		1.8	2.4	5.5	12.0	
	A1GaInP	Super Yellow	590	589		1.8	2.4	12.3	25.0	

SURFACE MOUNT DUAL-TRI COLOR LED LAMPS

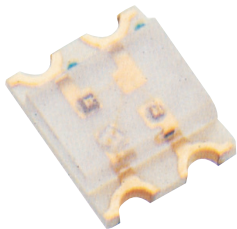

Absolute Maximum Ratings(Ta=25°C)

	UNIT	SPEC.
IF	mA	30
IFp	mA	100
VR	V	5
Topr	°C	-25~+80
Tstg	°C	-30~+85

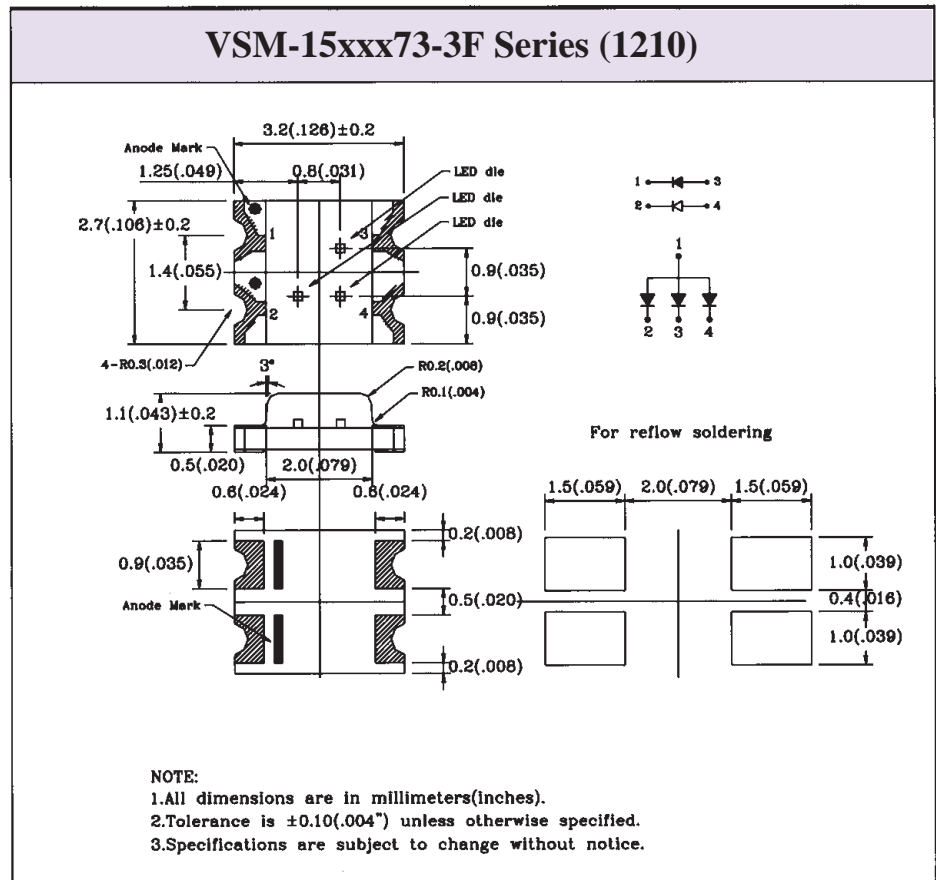

Part No.	Chip				Lens Appearance	Electro-optical Data (At 20mA)				Viewing Angle 2θ 1/2 (deg)
	Material	Emitted Color	λ p (nm)	λ d (nm)		Vf(V)		Iv(mcd)		
						Typ.	Max.	Min.	Typ.	
VSM-150R1673-3F	GaAlAs/GaAs	Super Red	660	643	Water Clear	1.8	2.6	8.2	20.0	120°
	GaP/GaP	Green	568	571		2.2	2.6	2.4	10.0	
VSM-1506G173-3F	GaAlAs/GaAs	Super Red	660	643		1.7	2.6	5.5	15.0	
	GaP/GaP	Hi-Eff Green	568	570		2.2	2.6	5.5	12.0	
VSM-150R26G273-3F	GaAlAs/GaAlAs	Super Red	660	643		2.1	2.6	18.5	35.0	
	AlGaInP	Yellow Green	573	571		2.2	2.6	28.0	45.0	
VSM-150R26G38B173-3F	GaAlAs/GaAs	Super Red	660	643		1.8	2.6	12.3	25.0	
	InGaN	Bluish Green	505	505		3.5	4.0	63.0	120.0	
	AlInGaN	Super Blue	470	470		3.5	4.0	28.0	40.0	
VSM-150R26G18B173-3F	GaAlAs/GaAs	Super Red	660	643		1.8	2.6	12.3	25.0	
	GaP/GaP	Hi-Eff Green	568	570		2.2	2.6	5.5	12.0	
	AlInGaN	Super Blue	470	470		3.5	4.0	28.0	40.0	

SURFACE MOUNT TRI COLOR LED LAMPS

VSM-15xxx73-3T Series (1210)

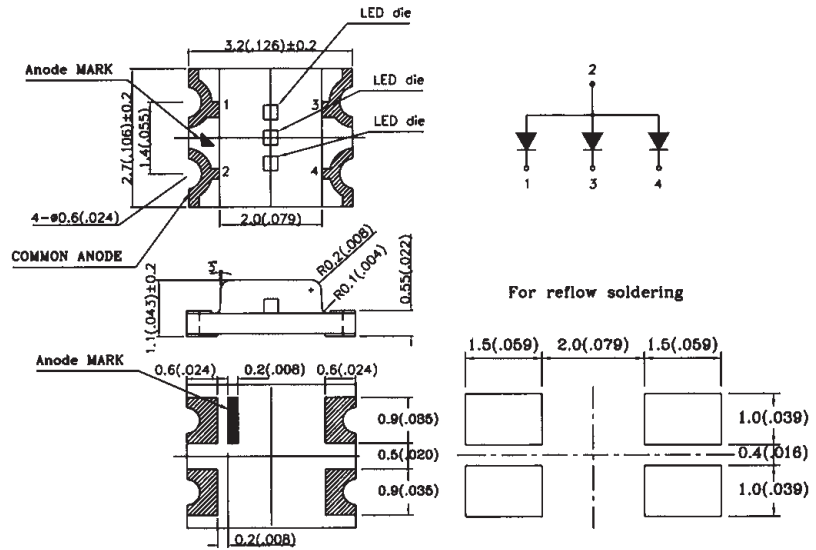

Absolute Maximum Ratings(Ta=25°C)

	UNIT	SPEC.
IF	mA	30
IFp	mA	100
VR	V	5
Topr	°C	-25~+80
Tstg	°C	-30~+85

NOTE:

- 1.All dimensions are in millimeters(inches).
- 2.Tolerance is ±0.10(.004") unless otherwise specified.
- 3.Specifications are subject to change without notice.

Part No.	Chip				Lens Appearance	Electro-optical Data (At 20mA)				Viewing Angle 2θ 1/2 (deg)
	Material	Emitted Color	λ p (nm)	λ d (nm)		Vf(V)		Iv(mcd)		
						Typ.	Max.	Min.	Typ.	
VSM-1506G38B173-3T	GaAlAs/GaAs	Super Red	660	643	Water Clear	1.8	2.6	12.3	25.0	120°
	InGaN	Bluish Green	505	505		3.5	4.0	63.0	120.0	
	AllnGaN	Super Blue	470	470		3.5	4.0	28.0	40.0	
VSM-1506G48B173-3T	GaAlAs/GaAs	Super Red	660	643		1.8	2.6	12.3	25.0	
	InGaN	Green	525	525		3.5	4.0	63.0	160.0	
	AllnGaN	Super Blue	470	470		3.5	4.0	28.0	40.0	
VSM-1506G18B173-3T	GaAlAs/GaAs	Super Red	660	643		1.8	2.6	12.3	25.0	
	GaP/GaP	Hi-Eff Green	568	570		2.2	2.6	5.5	12.0	
	AllnGaN	Super Blue	470	470		3.5	4.0	28.0	40.0	
VSM-1506G15Y173-3T	GaAlAs/GaAs	Super Red	660	643	1.8	2.6	12.3	25.0		
	GaP/GaP	Hi-Eff Green	568	570	2.2	2.6	5.5	12.0		
	A1GaInP	Super Yellow	590	587	2.1	2.6	28.0	45.0		
VSM-150R36G48B173-3T	A1GaInP	Super Red	645	632	2.1	2.6	28.0	50.0		
	InGaN	Green	525	525	3.5	4.0	63.0	160.0		
	AllnGaN	Super Blue	470	470	3.5	4.0	28.0	40.0		

SURFACE MOUNT TRI COLOR LED LAMPS



Absolute Maximum Ratings(Ta=25°C)

	UNIT	SPEC.
IF	mA	30
IFp	mA	100
VR	V	5
Topr	°C	-25~+80
Tstg	°C	-30~+85

VSM-10xxx73-3G Series

ANODE MARK

4-φ1.5(0.059)

1.0(0.039)

0.7(0.028)

1.5(0.059)

2.4(0.094)±0.2

0.0(0.000)

2.4(0.094)±0.2

0.75(0.03)

1.35(0.053)

1.90(0.075)

0.5(0.012)

0.8(0.031)±0.1

RO.05(0.002)

RO.05(0.002)

3°

COMMON ANODE

2

1 3 4

For reflow Soldering

2.7(0.106)

0.7(0.026)

0.7(0.028)

2.7(0.106)

NOTE:

- All dimensions are in millimeters(inches).
- Tolerance is ±0.10(.004") unless otherwise specified.
- Specifications are subject to change without notice.

Part No.	Chip				Lens Appearance	Electro-optical Data (At 20mA)				Viewing Angle 2θ 1/2 (deg)
	Material	Emitted Color	λ p (nm)	λ d (nm)		Vf(V)		Iv(mcd)		
						Typ.	Max.	Min.	Typ.	
VSM-106G44Q28B173-3G	InGaN	Green	525	525	Water Clear	3.5	4.0	63.0	120.0	140°
	AlGaInP	Super Orange	630	625		2.2	2.6	42.0	80.0	
	AlInGaN	Super Blue	470	470		3.5	4.0	28.0	40.0	
VSM-106G40R38B173-3G	InGaN	Green	525	525		3.5	4.0	63.0	120.0	
	AlGaInP	Super Red	645	632		2.1	2.6	28.0	50.0	
	AlInGaN	Super Blue	470	470		3.5	4.0	28.0	40.0	
VSM-104Q26G28B173-3G	AlGaInP	Super Orange Red	630	625		2.1	2.6	28.0	50.0	
	AlGaInP	Super Yellow Green	570	570		2.0	2.6	18.5	30.0	
	AlInGaN	Super Blue	470	470		3.5	4.0	28.0	40.0	
VSM-158B16G15Y173-3G	GaAlAs/GaAs	Super Red	660	643		1.8	2.6	12.3	25.0	
	GaP/GaP	Hi-Eff-Green	568	570		2.2	2.6	5.5	12.0	
	AlGaInP	Super Yellow	590	587		2.1	2.6	28.0	45.0	
VSM-1506G38B173-3G	GaAlAs/GaAs	Super Red	660	643	1.8	2.6	12.3	25.0		
	InGaN	Bluish Green	505	505	3.5	4.0	63.0	120.0		
	AlInGaN	Super Blue	470	470	3.5	4.0	28.0	40.0		



SURFACE MOUNT RESISTOR CHIP LED LAMPS

VSM-1573-xxV Series

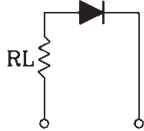
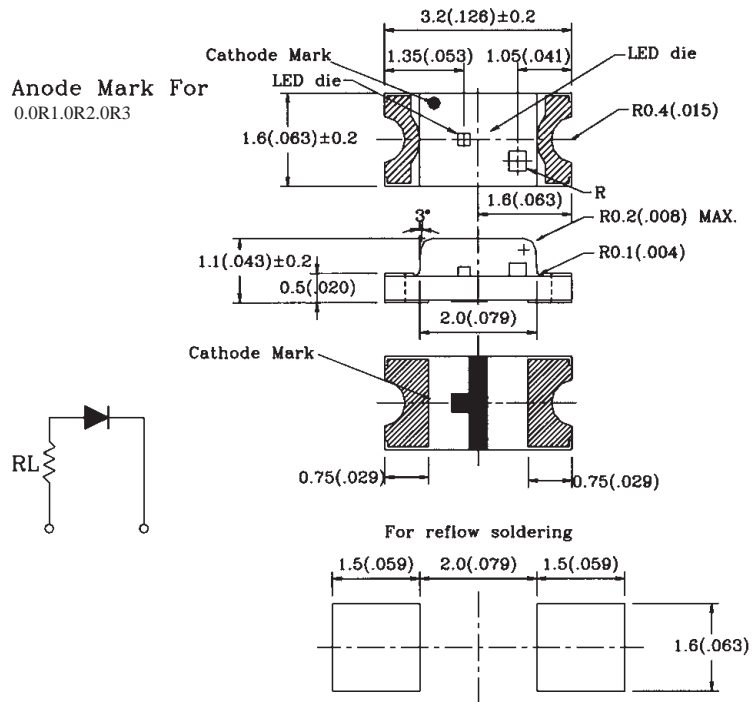

NOTE:
 1.All dimensions are in millimeters(inches).
 2.Tolerance is $\pm 0.10(.004)$ unless otherwise specified.
 3.Specifications are subject to change without notice.

Absolute Maximum Ratings($T_a=25^\circ\text{C}$)

	UNIT	SPEC.
IF	mA	12
IFp	mA	100
Topr	$^\circ\text{C}$	-45~+85
Tstg	$^\circ\text{C}$	-45~+100

Part No.	Chip			Lens Appearance	Electro-optical Data						Viewing Angle $2\theta_{1/2}$ (deg)
	Material	Emitted Color	λ_p (nm)		Operating Voltage		Forward Current		Iv(mcd)		
					Typ.	Max.	Typ.	Max.	Min.	Typ.	
VSM-15673-05V	GaP/GaP	Yellow Green	568	Water Clear	—	5	7	12	5.5	15.0	140°
VSM-15573-05V	GaAsP/GaP	Yellow	583		—	5	7	12	3.7	12.0	
VSM-15373-05V	GaAsP/GaP	Hi-Eff Red	640		—	5	7	12	5.5	15.0	
VSM-15073-05V	GaAlAs/GaAs	Super Red	660		—	5	7	12	12.3	30.0	
VSM-150R373-05V	AlGaInP	Super Red	645		—	5	7	12	12.3	25.0	
VSM-150R373-09V	AlGaInP	Super Red	645		—	9	7	12	12.3	25.0	
VSM-15673-12V	GaP/GaP	Yellow Green	568		—	12	7	12	5.5	15.0	
VSM-15573-12V	GaAsP/GaP	Yellow	583		—	12	7	12	3.7	12.0	
VSM-15373-12V	GaAsP/GaP	Hi-Eff Red	640		—	12	7	12	5.5	15.0	
VSM-15073-12V	GaAlAs/GaAs	Super Red	660		—	12	7	12	12.3	30.0	
VSM-15673-15V	GaP/GaP	Yellow Green	568		—	15	7	12	5.5	15.0	
VSM-15573-15V	GaAsP/GaP	Yellow	583		—	15	7	12	3.7	12.0	
VSM-15373-15V	GaAsP/GaP	Hi-Eff Red	640		—	15	7	12	5.5	15.0	

SURFACE MOUNT BLINKING CHIP LED LAMPS



Absolute Maximum Ratings(Ta=25°C)

	UNIT	SPEC.
IF	mA	20
IFp	mA	100
V _R	V	5.0
Topr	°C	-25~+80
Tstg	°C	-20~+85

VSM-15x73-C Series

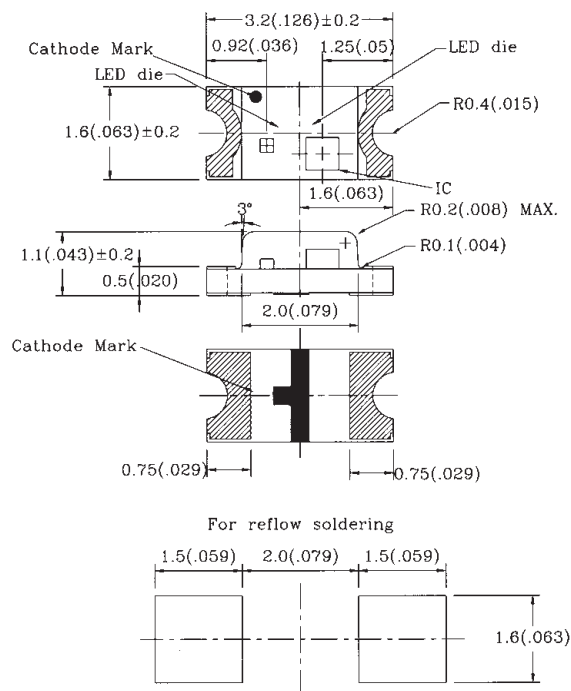

NOTE:
 1.All dimensions are in millimeters(inches).
 2.Tolerance is $\pm 0.10(.004)$ unless otherwise specified.
 3.Specifications are subject to change without notice.

Part No.	Chip			Lens Appearance	Forward Current		Pulse Rate(Hz) VDD=5V			I _v (mcd)		Viewing Angle 2θ 1/2 (deg)
	Material	Emitted Color	λ _p (nm)		Typ.	Max.	Min.	Typ.	Max.	Min.	Typ.	
VSM-15273-C	GaP/GaP	Bright Red	700	Water Clear	20	—	2.0	2.4	3.0	2.4	6.0	140°
VSM-15673-C	GaP/GaP	Yellow Green	568		20	—	2.0	2.4	3.0	8.2	25.0	
VSM-156G173-C	GaP/GaP	Hi-Eff Green	568		20	—	2.0	2.4	3.0	5.5	12.0	
VSM-156P73-C	GaP/GaP	Pure Green	557		20	—	2.0	2.4	3.0	1.6	3.0	
VSM-15573-C	GaAsP/GaP	Yellow	583		20	—	2.0	2.4	3.0	2.4	6.0	
VSM-15373-C	GaAsP/GaP	Hi-Eff Red	640		20	—	1.8	2.4	3.0	2.4	8.0	
VSM-150R273-C	GaAlAs	Super Red	660		20	—	2.0	2.4	3.0	8.2	25.0	
VSM-154Q173-C	AlGaInP	Super Orange	620		20	—	2.0	2.4	3.0	28.0	50.0	
VSM-155Y173-C	AlGaInP	Super Yellow	590		20	—	2.0	2.4	3.0	28.0	40.0	
VSM-154E273-C	AlGaInP	Soft Orange	630		20	—	2.0	2.4	3.0	42.0	70.0	
VSM-154F173-C	AlGaInP	Soft Orange	610		20	—	2.0	2.4	3.0	28.0	50.0	
VSM-150R373-C	AlGaInP	Super Red	645		20	—	2.0	2.4	3.0	28.0	50.0	

AXIAL LED LAMPS



Absolute Maximum Ratings(Ta=25°C)

	UNIT	SPEC.
IF	mA	30
IFp	mA	100
VR	V	5
Topr	°C	-25→+80
Tstg	°C	-30→+85

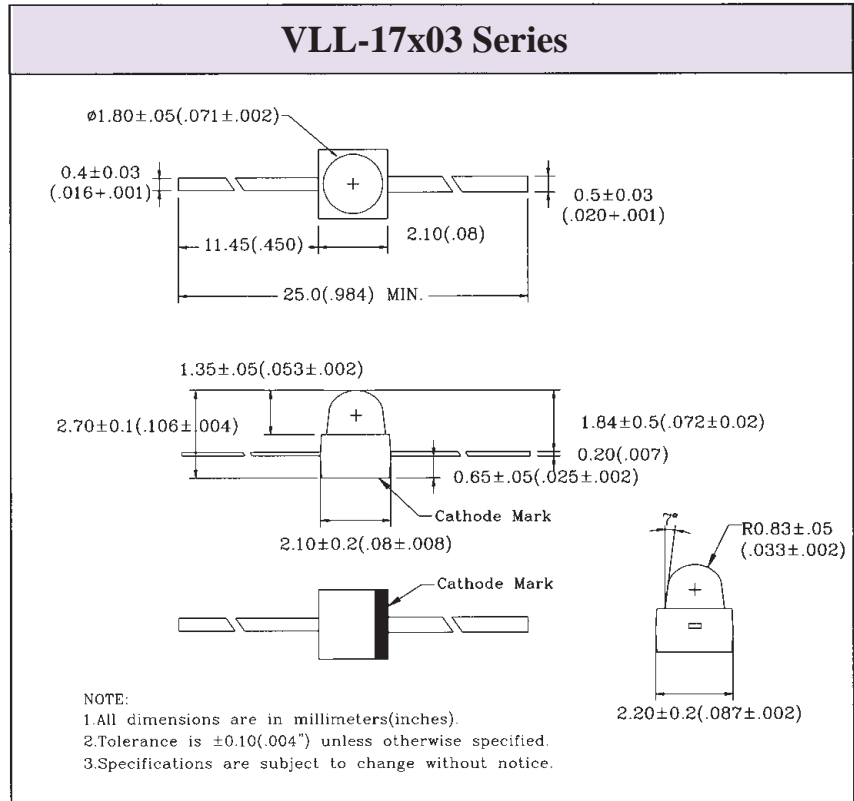

Part No.	Chip				Lens Appearance	Electro-optical Data (At 20mA)				Viewing Angle 2θ 1/2 (deg)
	Material	Emitted Color	λ p (nm)	λ d (nm)		Vf(V)		Iv(mcd)		
						Typ.	Max.	Min.	Typ.	
VLL-17303	GaAsP/GaP	Hi-Eff Red	640	628	Water Clear	2.0	2.6	18.5	40.0	35°
VLL-17003	GaAlAs/GaAs	Super Red	660	643		1.7	2.6	28.0	60.0	
VLL-170R103	GaAlAs/GaAs	Super Red	660	643		1.8	2.6	28.0	75.0	
VLL-170R203	GaAlAs	Super Red	660	643		2.1	2.6	42.0	100.0	
VLL-170R303	AlGaInP	Super Red	645	632		2.1	2.6	42.0	100.0	
VLL-1740103	AlGaInP	Super Orange Red	620	615		2.2	2.6	63.0	150.0	
VLL-1740203	AlGaInP	Super Orange Red	630	625		2.1	2.6	63.0	150.0	
VLL-17603	GaP/GaP	Yellow Green	568	571		2.1	2.6	18.5	45.0	
VLL-176G103	GaP/GaP	Hi-Eff Green	568	570		2.0	2.6	28.0	55.0	
VLL-176P03	GaP/GaP	Pure Green	557	563		2.2	2.6	5.5	15.0	
VLL-176G203	AlGaInP	Super Yellow Green	570	570		2.0	2.6	42.0	80.0	
VLL-176G303	InGaN	Bluish Green	505	505		3.5	4.0	94.0	250.0	
VLL-176G403	InGaN	Green	525	525		3.5	4.0	94.0	300.0	
VLL-17503	GaAsP/GaP	Yellow	583	585		2.1	2.6	12.3	30.0	
VLL-175Y103	AlGaInP	Super Yellow	590	587		2.1	2.6	94.0	200.0	
VLL-175Y203	AlGaInP	Super Yellow	595	594		2.1	2.6	94.0	200.0	
VLL-17703	GaAsP/GaP	Amber	610	610		2.2	2.6	5.5	15.0	
VLL-177A103	AlGaInP	Super Amber	610	605		2.0	2.6	63.0	150.0	

Part No.	Chip				Lens Appearance	Electro-optical Data (At 5mA)				Viewing Angle 2θ 1/2 (deg)
	Material	Emitted Color	λ p (nm)	λ d (nm)		Vf(V)		Iv(mcd)		
						Typ.	Max.	Min.	Typ.	
VLL-17803	AlInGaN	Super Blue	460	465-470	Water Clear	2.8	3.2	28.0	60.0	35°
VLL-178B103	AlInGaN	Super Blue	470	470-475		2.8	3.2	28.0	70.0	

AXIAL LED LAMPS WITH " GULL WING" LEAD

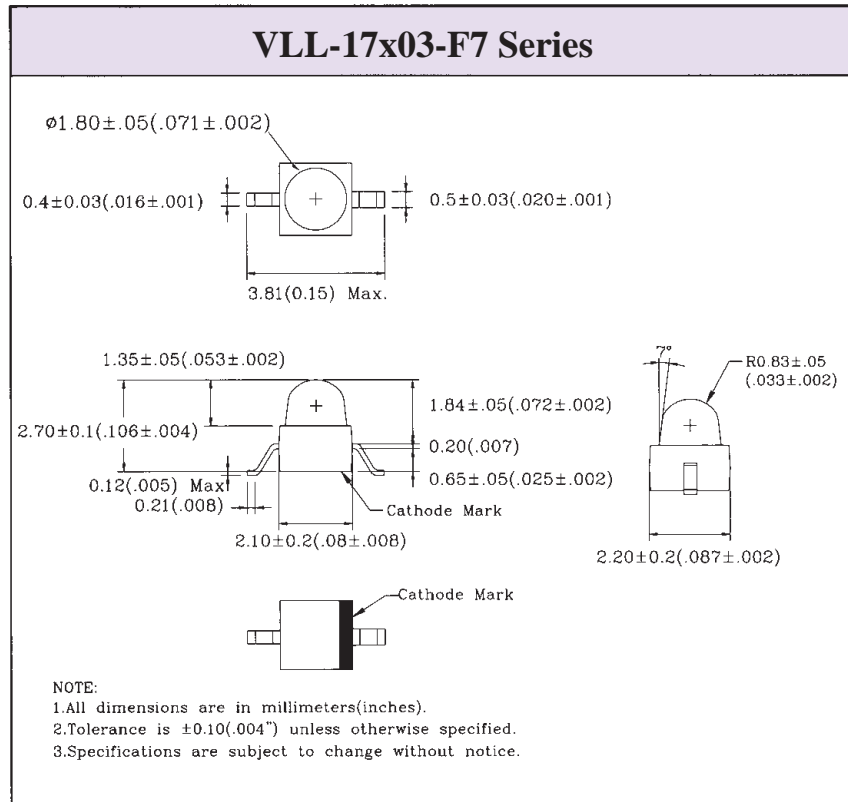

Absolute Maximum Ratings (Ta=25°C)

	UNIT	SPEC.
IF	mA	30
IFp	mA	100
VR	V	5
Topr	°C	-25~+80
Tstg	°C	-30~+85

Part No.	Chip				Lens Appearance	Electro-optical Data (At 20mA)				Viewing Angle $2\theta 1/2$ (deg)
	Material	Emitted Color	λ_p (nm)	λ_d (nm)		Vf(V)		Iv(mcd)		
						Typ.	Max.	Min.	Typ.	
VLL-17303-F7	GaAsP/GaP	Hi-Eff Red	640	628	Water Clear	2.0	2.6	18.5	40.0	35°
VLL-17003-F7	GaAlAs/GaAs	Super Red	660	643		1.7	2.6	28.0	60.0	
VLL-170R103-F7	GaAlAs/GaAs	Super Red	660	643		1.8	2.6	28.0	75.0	
VLL-170R203-F7	GaAlAs	Super Red	660	643		2.1	2.6	42.0	100.0	
VLL-170R303-F7	AlGaInP	Super Red	645	632		2.1	2.6	42.0	100.0	
VLL-174Q103-F7	AlGaInP	Super Orange Red	620	615		2.0	2.6	63.0	150.0	
VLL-174Q203-F7	AlGaInP	Super Orange Red	630	625		2.1	2.6	63.0	150.0	
VLL-17603-F7	GaP/GaP	Yellow Green	568	571		2.1	2.6	18.5	45.0	
VLL-176G103-F7	GaP/GaP	Hi-Eff Green	568	570		2.2	2.6	28.0	55.0	
VLL-176P03-F7	GaP/GaP	Pure Green	557	563		2.2	2.6	5.5	15.0	
VLL-176G203-F7	AlGaInP	Super Yellow Green	570	570		2.0	2.6	42.0	80.0	
VLL-176G303-F7	InGaN	Bluish Green	505	505		3.5	4.0	94.0	250.0	
VLL-176G403-F7	InGaN	Green	525	525		3.5	4.0	94.0	300.0	
VLL-17503-F7	GaAsP/GaP	Yellow	583	585		2.1	2.6	12.3	30.0	
VLL-175Y103-F7	AlGaInP	Super Yellow	590	587		2.1	2.6	94.0	200.0	
VLL-175Y203-F7	AlGaInP	Super Yellow	595	594		2.1	2.6	94.0	200.0	
VLL-17703-F7	GaAsP/GaP	Amber	610	610		2.2	2.6	5.5	15.0	
VLL-177A103-F7	AlGaInP	Super Amber	610	605		2.0	2.6	63.0	150.0	

Part No.	Chip				Lens Appearance	Electro-optical Data (At 5mA)				Viewing Angle $2\theta 1/2$ (deg)
	Material	Emitted Color	λ_p (nm)	λ_d (nm)		Vf(V)		Iv(mcd)		
						Typ.	Max.	Min.	Typ.	
VLL-17803-F7	AlInGaN	Super Blue	460	465-470	Water Clear	2.8	3.2	28.0	60.0	35°
VLL-178B103-F7	AlInGaN	Super Blue	470	470-475		2.8	3.2	28.0	70.0	

AXIAL LED LAMPS WITH "Z" BENT LEAD

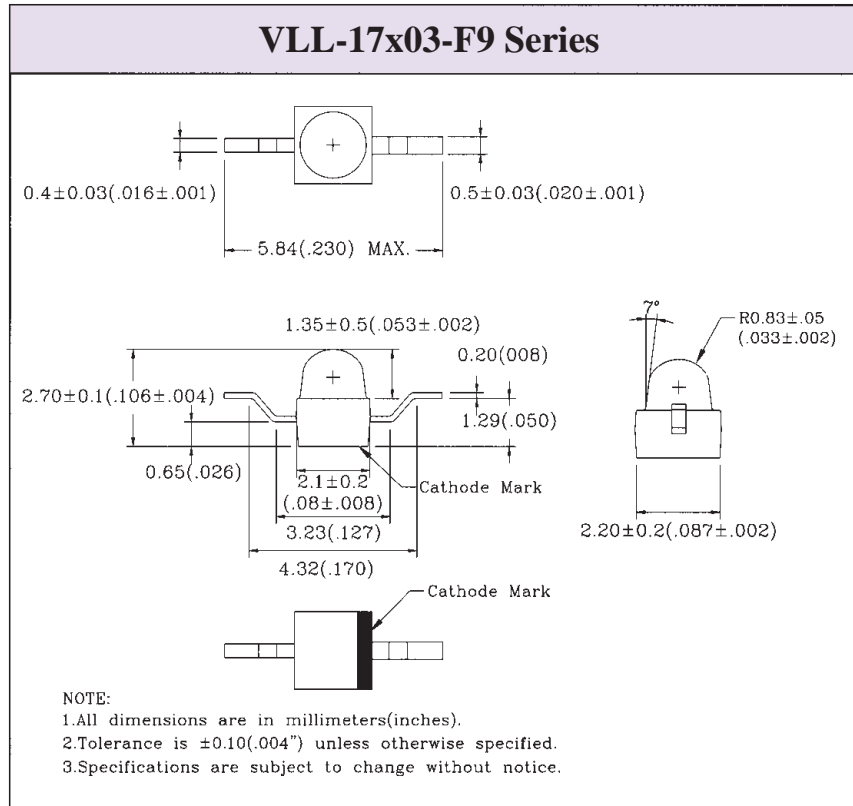

Absolute Maximum Ratings (Ta=25°C)

	UNIT	SPEC.
IF	mA	30
IFp	mA	100
VR	V	5
Topr	°C	-25~+80
Tstg	°C	-30~+85

Part No.	Chip				Lens Appearance	Electro-optical Data (At 20mA)				Viewing Angle 2θ 1/2 (deg)
	Material	Emitted Color	λ p (nm)	λ d (nm)		Vf(V)		Iv(mcd)		
						Typ.	Max.	Min.	Typ.	
VLL-17303-F9	GaAsP/GaP	Hi-Eff Red	640	628	Water Clear	2.0	2.6	18.5	40.0	35°
VLL-17003-F9	GaAlAs/GaAs	Super Red	660	643		1.7	2.6	28.0	60.0	
VLL-170R103-F9	GaAlAs/GaAs	Super Red	660	643		1.8	2.6	28.0	75.0	
VLL-170R203-F9	GaAlAs	Super Red	660	643		2.1	2.6	42.0	100.0	
VLL-170R303-F9	AlGaInP	Super Red	645	632		2.1	2.6	42.0	100.0	
VLL-1740103-F9	AlGaInP	Super Orange Red	620	615		2.0	2.6	63.0	150.0	
VLL-1740203-F9	AlGaInP	Super Orange Red	630	625		2.1	2.6	63.0	150.0	
VLL-17603-F9	GaP/GaP	Yellow Green	568	571		2.1	2.6	18.5	45.0	
VLL-176G103-F9	GaP/GaP	Hi-Eff Green	568	570		2.2	2.6	28.0	55.0	
VLL-176P03-F9	GaP/GaP	Pure Green	557	563		2.2	2.6	5.5	15.0	
VLL-176G203-F9	AlGaInP	Super Yellow Green	570	570		2.0	2.6	42.0	80.0	
VLL-176G303-F9	InGaN	Bluish Green	505	505		3.5	4.0	94.0	250.0	
VLL-176G403-F9	InGaN	Green	525	525		3.5	4.0	94.0	300.0	
VLL-17503-F9	GaAsP/GaP	Yellow	583	585		2.1	2.6	12.3	30.0	
VLL-175Y103-F9	AlGaInP	Super Yellow	590	587		2.1	2.6	94.0	200.0	
VLL-175Y203-F9	AlGaInP	Super Yellow	595	594		2.1	2.6	94.0	200.0	
VLL-17703-F9	GaAsP/GaP	Amber	610	610		2.2	2.6	5.5	15.0	
VLL-177A103-F9	AlGaInP	Super Amber	610	605		2.0	2.6	63.0	150.0	

Part No.	Chip				Lens Appearance	Electro-optical Data (At 5mA)				Viewing Angle 2θ 1/2 (deg)
	Material	Emitted Color	λ p (nm)	λ d (nm)		Vf(V)		Iv(mcd)		
						Typ.	Max.	Min.	Typ.	
VLL-17803-F9	AlInGaIn	Super Blue	460	465-470	Water Clear	2.8	3.2	28.0	60.0	35°
VLL-178B103-F9	AlInGaIn	Super Blue	470	470-475		2.8	3.2	28.0	70.0	



TAPE AND REEL SURFACE MOUNT CHIP LED LAMPS

- DEVICE NUMBER: VSM-15x73-N
- FEATURES:
 - Compatible with automatic placement equipment
 - Surface Mount assembly lamp
 - High efficiency low power consumption
 - Long life solid state reliability
- TAPPING AND PACKAGING SPECIFICATION

ITEM	SYMBOL	SPECIFICATION			
		Minimum		Maximum	
		mm	inch	mm	inch
Tape Feed Hole Diameter (DIA)	D ₀	1.40	0.055	1.60	0.063
Feed Hole Location	E	1.65	0.064	1.85	0.073
Centers Line Dimensions Length Direction	F	3.45	0.135	3.55	0.139
Compartment Depth	K ₀	1.17	0.046	1.37	0.054
Compartment Pitch	P	3.90	0.153	4.10	0.161
Sprocket Hole Diameter	P ₀	3.90	0.153	4.10	0.161
Centers Line Dimensions Length Direction	P ₂	1.95	0.076	2.05	0.080
Carrier Tape Thickness	t	—	—	0.30	0.012
Carrier Tape Width	W	7.70	0.303	8.30	0.326
Flange Diameter	A	178.0	7.008	180.0	7.087
Hub Spindle Hole	C	12.50	0.492	13.50	0.531
Hub Diameter	D ₂	70.00	2.755	72.00	2.830
Fixing Tape Width	W ₁	5.25	0.206	5.35	0.210
Flange Space Between Flanges	T	12.50	0.492	13.50	0.531
Compartment Length	A ₀	1.78	0.070	1.98	0.078
Compartment Width	B ₀	3.40	0.134	3.60	0.142

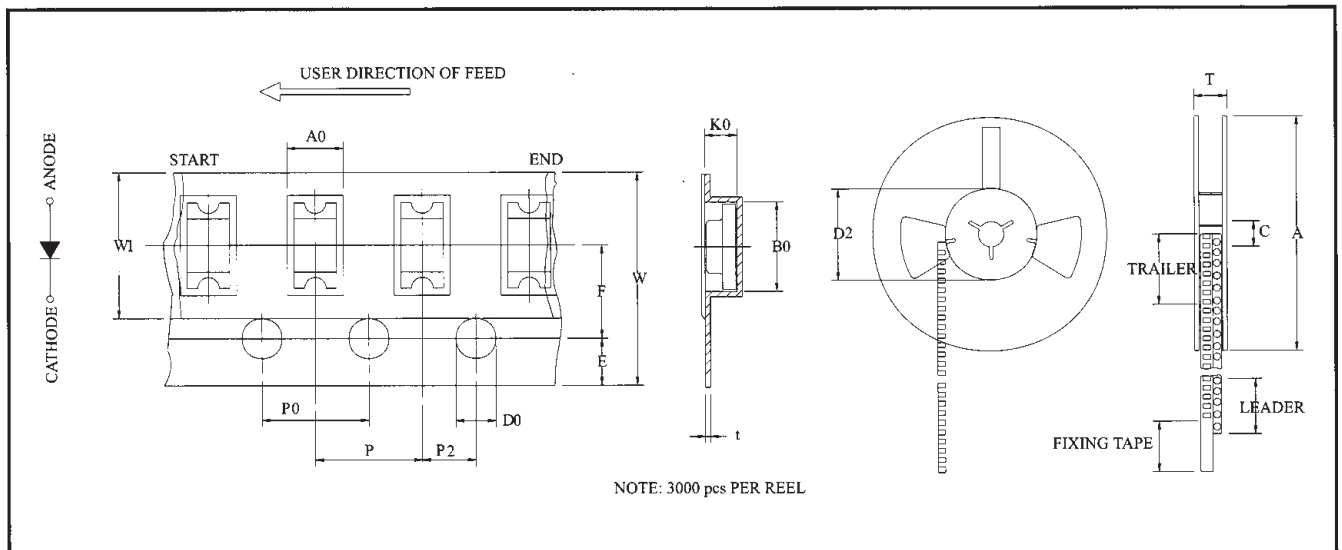



TAPE AND REEL SURFACE MOUNT CHIP LED LAMPS

- DEVICE NUMBER: VSM-15x73
- FEATURES:
 - Compatible with automatic placement equipment
 - Surface Mount assembly lamp
 - High efficiency low power consumption
 - Long life solid state reliability
- TAPPING AND PACKAGING SPECIFICATION

ITEM	SYMBOL	SPECIFICATION			
		Minimum		Maximum	
		mm	inch	mm	inch
Tape Feed Hole Diameter (DIA)	D ₀	1.40	0.055	1.60	0.063
Feed Hole Location	E	1.65	0.064	1.85	0.073
Centers Line Dimensions Length Direction	F	3.45	0.135	3.55	0.139
Compartment Depth	K ₀	1.36	0.054	1.56	0.061
Compartment Pitch	P	3.90	0.153	4.10	0.161
Sprocket Hole Diameter	P ₀	3.90	0.153	4.10	0.161
Centers Line Dimensions Length Direction	P ₂	1.95	0.076	2.05	0.080
Carrier Tape Thickness	t	—	—	0.30	0.012
Carrier Tape Width	W	7.70	0.303	8.30	0.326
Flange Diameter	A	178.0	7.008	180.0	7.087
Hub Spindle Hole	C	12.50	0.492	13.50	0.531
Hub Diameter	D ₂	70.00	2.755	72.00	2.830
Fixing Tape Width	W ₁	5.25	0.206	5.35	0.210
Flange Space Between Flanges	T	12.50	0.492	13.50	0.531
Compartment Length	A ₀	1.88	0.074	2.08	0.082
Compartment Width	B ₀	3.37	0.133	3.57	0.141

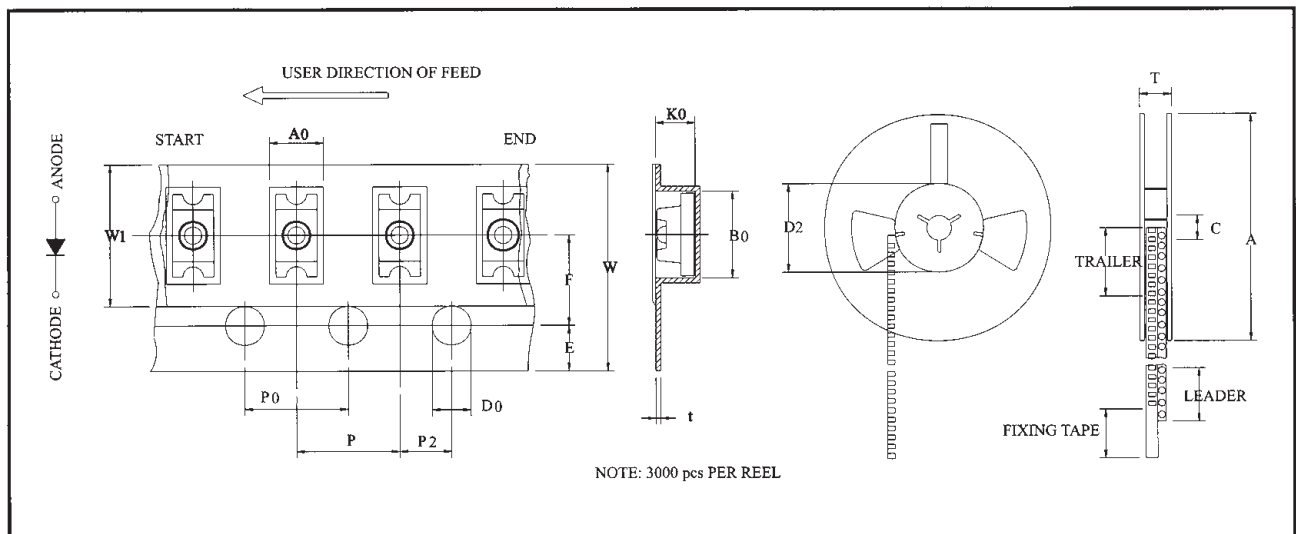



TAPE AND REEL SURFACE MOUNT CHIP LED LAMPS

- DEVICE NUMBER: VSM-15x73-4A
- FEATURES:
 - Compatible with automatic placement equipment
 - Surface Mount assembly lamp
 - High efficiency low power consumption
 - Long life solid state reliability
- TAPPING AND PACKAGING SPECIFICATION

ITEM	SYMBOL	SPECIFICATION			
		Minimum		Maximum	
		mm	inch	mm	inch
Tape Feed Hole Diameter (DIA)	D ₀	1.40	0.055	1.60	0.063
Feed Hole Location	E	1.65	0.064	1.85	0.073
Centers Line Dimensions Length Direction	F	3.45	0.135	3.55	0.139
Compartment Depth	K ₀	1.20	0.047	1.40	0.055
Compartment Pitch	P	3.90	0.153	4.10	0.161
Sprocket Hole Diameter	P ₀	3.90	0.153	4.10	0.161
Centers Line Dimensions Length Direction	P ₂	1.95	0.076	2.05	0.080
Carrier Tape Thickness	t	—	—	0.30	0.012
Carrier Tape Width	W	7.70	0.303	8.30	0.326
Flange Diameter	A	178.0	7.008	180.0	7.087
Hub Spindle Hole	C	12.50	0.492	13.50	0.531
Hub Diameter	D ₂	70.00	2.755	72.00	2.830
Fixing Tape Width	W ₁	5.25	0.206	5.35	0.210
Flange Space Between Flanges	T	16.00	0.629	18.40	0.724
Compartment Length	A ₀	2.20	0.087	2.40	0.094
Compartment Width	B ₀	3.20	0.126	3.40	0.134

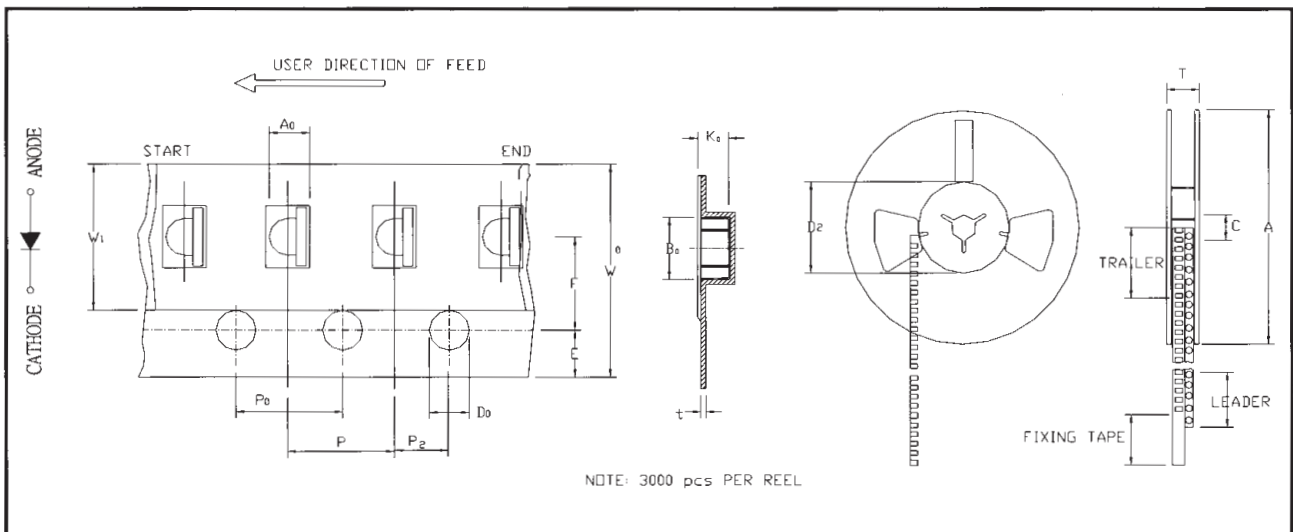



TAPE AND REEL SURFACE MOUNT CHIP LED LAMPS

- DEVICE NUMBER: VSM-15x73-4C
- FEATURES:
 - Compatible with automatic placement equipment
 - Surface Mount assembly lamp
 - High efficiency low power consumption
 - Long life solid state reliability
- TAPPING AND PACKAGING SPECIFICATION

ITEM	SYMBOL	SPECIFICATION			
		Minimum		Maximum	
		mm	inch	mm	inch
Tape Feed Hole Diameter (DIA)	D ₀	1.40	0.055	1.60	0.063
Feed Hole Location	E	1.65	0.064	1.85	0.073
Centers Line Dimensions Length Direction	F	3.45	0.135	3.55	0.139
Compartment Depth	K ₀	1.12	0.044	1.32	0.052
Compartment Pitch	P	3.90	0.153	4.10	0.161
Sprocket Hole Diameter	P ₀	3.90	0.153	4.10	0.161
Centers Line Dimensions Length Direction	P ₂	1.95	0.076	2.05	0.080
Carrier Tape Thickness	t	—	—	0.30	0.012
Carrier Tape Width	W	7.70	0.303	8.30	0.326
Flange Diameter	A	178.0	7.008	180.0	7.087
Hub Spindle Hole	C	12.50	0.492	13.50	0.531
Hub Diameter	D ₂	70.00	2.755	72.00	2.830
Fixing Tape Width	W ₁	5.25	0.206	5.35	0.210
Flange Space Between Flanges	T	12.50	0.492	13.50	0.531
Compartment Length	A ₀	1.78	0.070	1.98	0.078
Compartment Width	B ₀	3.33	0.131	3.53	0.139

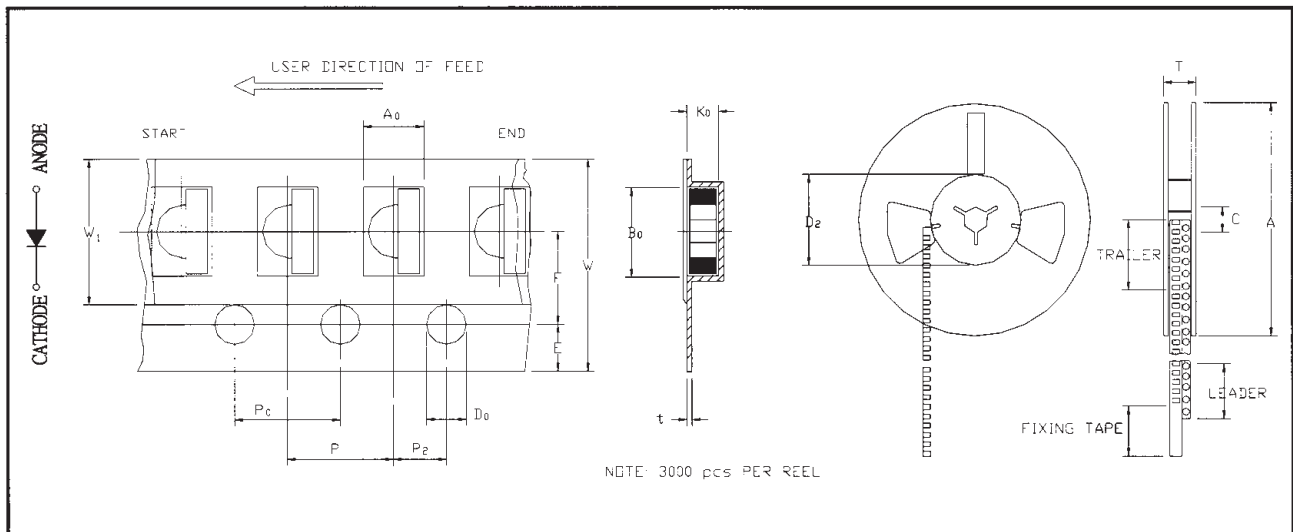



TAPE AND REEL SURFACE MOUNT CHIP LED LAMPS

- DEVICE NUMBER: VSM-11x73
- FEATURES:
 - Compatible with automatic placement equipment
 - Surface Mount assembly lamp
 - High efficiency low power consumption
 - Long life solid state reliability
- TAPPING AND PACKAGING SPECIFICATION

ITEM	SYMBOL	SPECIFICATION			
		Minimum		Maximum	
		mm	inch	mm	inch
Tape Feed Hole Diameter (DIA)	D ₀	1.40	0.055	1.60	0.063
Feed Hole Location	E	1.65	0.064	1.85	0.073
Centers Line Dimensions Length Direction	F	3.45	0.135	3.55	0.139
Compartment Depth	K ₀	1.17	0.046	1.37	0.054
Compartment Pitch	P	3.90	0.153	4.10	0.161
Sprocket Hole Diameter	P ₀	3.90	0.153	4.10	0.161
Centers Line Dimensions Length Direction	P ₂	1.95	0.076	2.05	0.080
Carrier Tape Thickness	t	—	—	0.30	0.012
Carrier Tape Width	W	7.70	0.303	8.30	0.326
Flange Diameter	A	178.0	7.008	180.0	7.087
Hub Spindle Hole	C	12.50	0.492	13.50	0.531
Hub Diameter	D ₂	70.00	2.755	72.00	2.830
Fixing Tape Width	W ₁	5.25	0.206	5.35	0.210
Flange Space Between Flanges	T	12.50	0.492	13.50	0.531
Compartment Length	A ₀	1.00	0.039	1.20	0.047
Compartment Width	B ₀	2.15	0.085	2.35	0.093

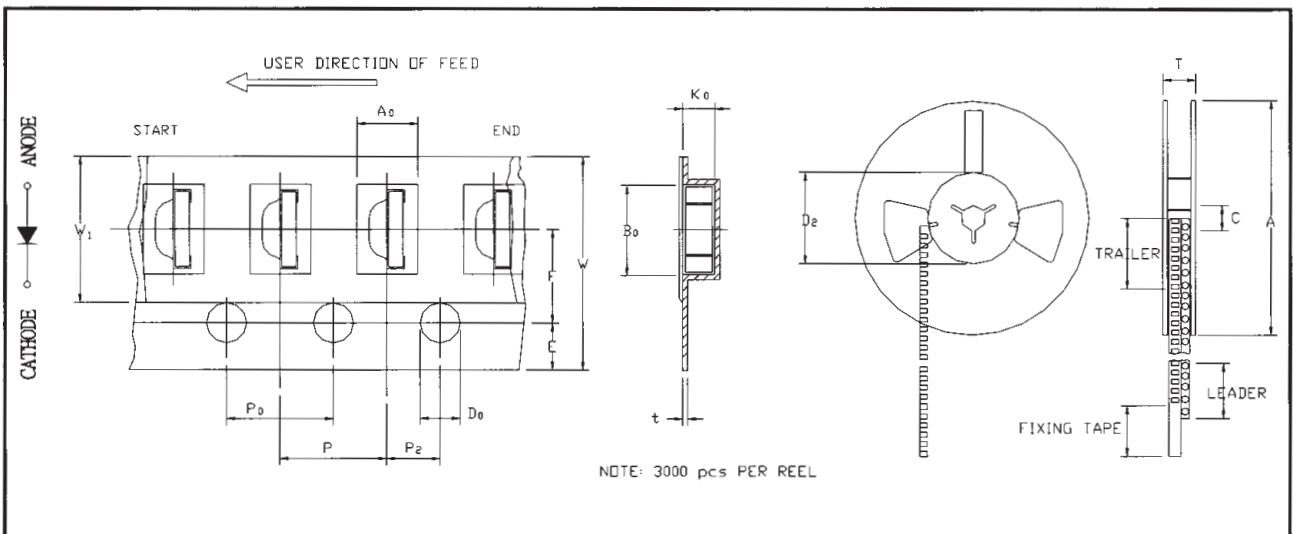



TAPE AND REEL SURFACE MOUNT CHIP LED LAMPS

- DEVICE NUMBER: VSM-12x73
- FEATURES:
 - Compatible with automatic placement equipment
 - Surface Mount assembly lamp
 - High efficiency low power consumption
 - Long life solid state reliability
- TAPPING AND PACKAGING SPECIFICATION

ITEM	SYMBOL	SPECIFICATION			
		Minimum		Maximum	
		mm	inch	mm	inch
Tape Feed Hole Diameter (DIA)	D ₀	1.40	0.055	1.60	0.063
Feed Hole Location	E	1.65	0.064	1.85	0.073
Centers Line Dimensions Length Direction	F	3.45	0.135	3.55	0.139
Compartment Depth	K ₀	1.20	0.047	1.40	0.055
Compartment Pitch	P	3.90	0.153	4.10	0.161
Sprocket Hole Diameter	P ₀	3.90	0.153	4.10	0.161
Centers Line Dimensions Length Direction	P ₂	1.95	0.076	2.05	0.080
Carrier Tape Thickness	t	—	—	0.30	0.012
Carrier Tape Width	W	7.70	0.303	8.30	0.326
Flange Diameter	A	178.0	7.008	180.0	7.087
Hub Spindle Hole	C	12.50	0.492	13.50	0.531
Hub Diameter	D ₂	70.00	2.755	72.00	2.830
Fixing Tape Width	W ₁	5.25	0.206	5.35	0.210
Flange Space Between Flanges	T	12.50	0.492	13.50	0.531
Compartment Length	A ₀	1.32	0.052	1.52	0.060
Compartment Width	B ₀	2.16	0.085	2.36	0.093

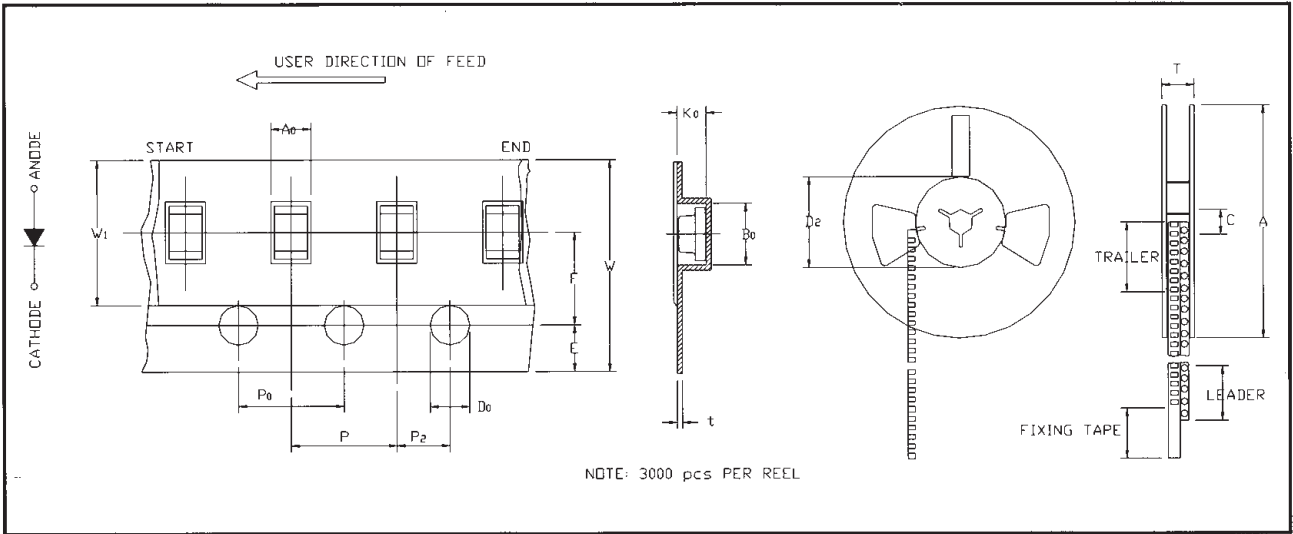



TAPE AND REEL SURFACE MOUNT CHIP LED LAMPS

- DEVICE NUMBER: VSM-10x73-6D
- FEATURES:
 - Compatible with automatic placement equipment
 - Surface Mount assembly lamp
 - High efficiency low power consumption
 - Long life solid state reliability
- TAPPING AND PACKAGING SPECIFICATION

ITEM	SYMBOL	SPECIFICATION			
		Minimum		Maximum	
		mm	inch	mm	inch
Tape Feed Hole Diameter (DIA)	D_0	1.40	0.055	1.60	0.063
Feed Hole Location	E	1.65	0.064	1.85	0.073
Centers Line Dimensions Length Direction	F	3.45	0.135	3.55	0.139
Compartment Depth	K_0	0.94	0.037	1.14	0.045
Compartment Pitch	P	3.90	0.153	4.10	0.161
Sprocket Hole Diameter	P_0	3.90	0.153	4.10	0.161
Centers Line Dimensions Length Direction	P_2	1.95	0.076	2.05	0.080
Carrier Tape Thickness	t	—	—	0.30	0.012
Carrier Tape Width	W	7.70	0.303	8.30	0.326
Flange Diameter	A	178.0	7.008	180.0	7.087
Hub Spindle Hole	C	12.50	0.492	13.50	0.531
Hub Diameter	D_2	70.00	2.755	72.00	2.830
Fixing Tape Width	W_1	5.25	0.206	5.35	0.210
Flange Space Between Flanges	T	12.50	0.492	13.50	0.531
Compartment Length	A_0	0.98	0.039	1.18	0.046
Compartment Width	B_0	1.78	0.070	1.98	0.078

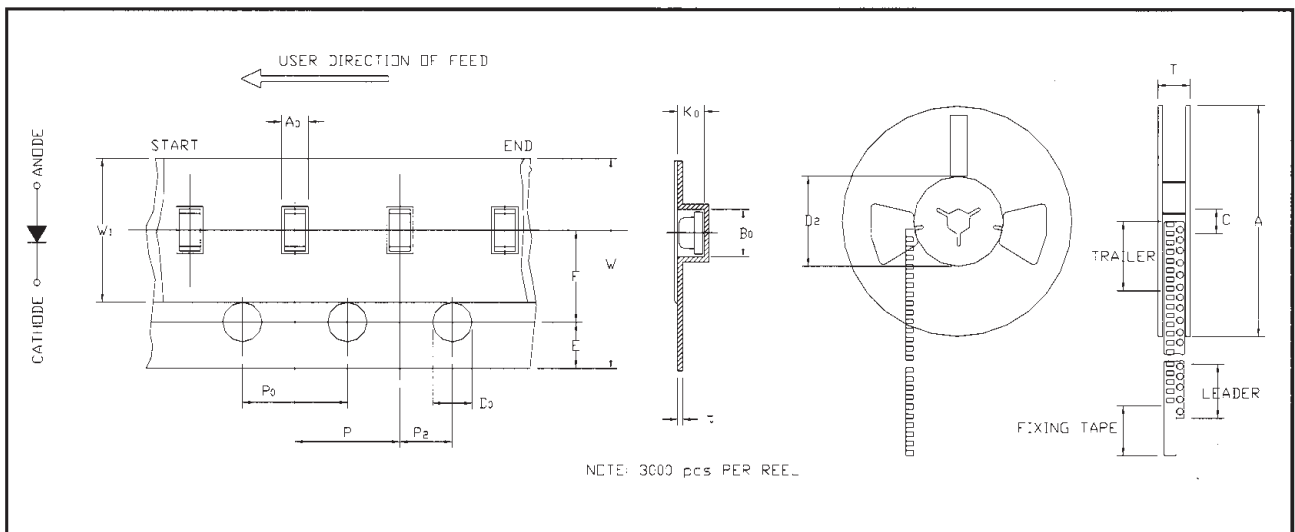



TAPE AND REEL SURFACE MOUNT CHIP LED LAMPS

- DEVICE NUMBER: VSM-10x73-6A
- FEATURES:
 - Compatible with automatic placement equipment
 - Surface Mount assembly lamp
 - High efficiency low power consumption
 - Long life solid state reliability
- TAPPING AND PACKAGING SPECIFICATION

ITEM	SYMBOL	SPECIFICATION			
		Minimum		Maximum	
		mm	inch	mm	inch
Tape Feed Hole Diameter (DIA)	D ₀	1.40	0.055	1.60	0.063
Feed Hole Location	E	1.65	0.064	1.85	0.073
Centers Line Dimensions Length Direction	F	3.45	0.135	3.55	0.139
Compartment Depth	K ₀	0.65	0.026	0.75	0.030
Compartment Pitch	P	3.90	0.153	4.10	0.161
Sprocket Hole Diameter	P ₀	3.90	0.153	4.10	0.161
Centers Line Dimensions Length Direction	P ₂	1.95	0.076	2.05	0.080
Carrier Tape Thickness	t	—	—	0.30	0.012
Carrier Tape Width	W	7.70	0.303	8.30	0.326
Flange Diameter	A	178.0	7.008	180.0	7.087
Hub Spindle Hole	C	12.50	0.492	13.50	0.531
Hub Diameter	D ₂	70.00	2.755	72.00	2.830
Fixing Tape Width	W ₁	5.25	0.206	5.35	0.210
Flange Space Between Flanges	T	12.50	0.492	13.50	0.531
Compartment Length	A ₀	0.85	0.033	0.95	0.037
Compartment Width	B ₀	1.70	0.067	1.80	0.071

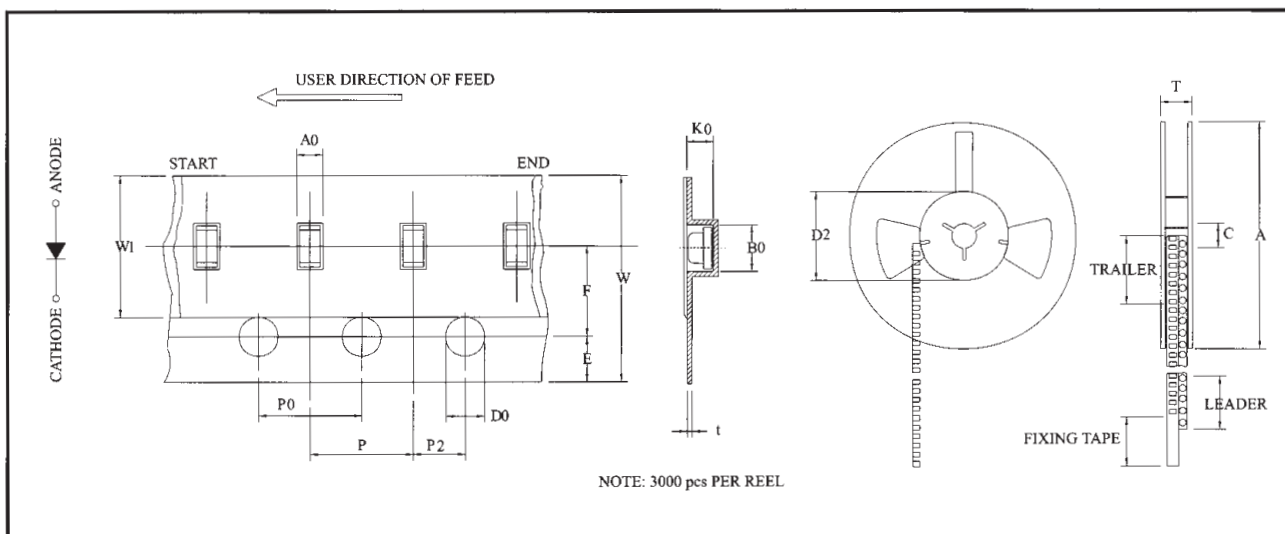



TAPE AND REEL SURFACE MOUNT CHIP LED LAMPS

- DEVICE NUMBER: VSM-10x73-6G
- FEATURES:
 - Compatible with automatic placement equipment
 - Surface Mount assembly lamp
 - High efficiency low power consumption
 - Long life solid state reliability
- TAPPING AND PACKAGING SPECIFICATION

ITEM	SYMBOL	SPECIFICATION			
		Minimum		Maximum	
		mm	inch	mm	inch
Tape Feed Hole Diameter (DIA)	D ₀	1.40	0.055	1.60	0.063
Feed Hole Location	E	1.65	0.064	1.85	0.073
Centers Line Dimensions Length Direction	F	3.45	0.135	3.55	0.139
Compartment Depth	K ₀	0.45	0.018	0.55	0.022
Compartment Pitch	P	3.90	0.153	4.10	0.161
Sprocket Hole Diameter	P ₀	3.90	0.153	4.10	0.161
Centers Line Dimensions Length Direction	P ₂	1.95	0.076	2.05	0.080
Carrier Tape Thickness	t	—	—	0.30	0.012
Carrier Tape Width	W	7.70	0.303	8.30	0.326
Flange Diameter	A	178.0	7.008	180.0	7.087
Hub Spindle Hole	C	12.50	0.492	13.50	0.531
Hub Diameter	D ₂	70.00	2.755	72.00	2.830
Fixing Tape Width	W ₁	5.25	0.206	5.35	0.210
Flange Space Between Flanges	T	12.50	0.492	13.50	0.531
Compartment Length	A ₀	0.85	0.033	0.95	0.037
Compartment Width	B ₀	1.70	0.067	1.80	0.071

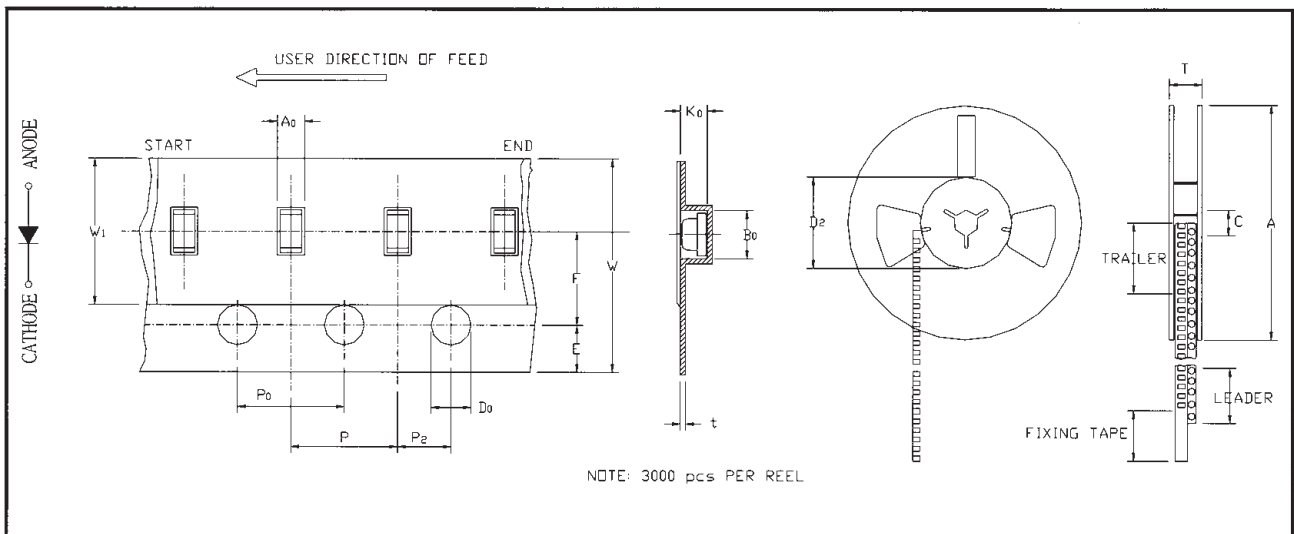



TAPE AND REEL SURFACE MOUNT CHIP LED LAMPS

- DEVICE NUMBER: VSM-15xx73-3B ,VSM-15xx73-3F ,VSM-15xxx73-3T
- FEATURES:
 - Compatible with automatic placement equipment
 - Surface Mount assembly lamp
 - High efficiency low power consumption
 - Long life solid state reliability
- TAPPING AND PACKAGING SPECIFICATION

ITEM	SYMBOL	SPECIFICATION			
		Minimum		Maximum	
		mm	inch	mm	inch
Tape Feed Hole Diameter (DIA)	D ₀	1.40	0.055	1.60	0.063
Feed Hole Location	E	1.65	0.064	1.85	0.073
Centers Line Dimensions Length Direction	F	3.45	0.135	3.55	0.139
Compartment Depth	K ₀	1.17	0.046	1.37	0.054
Compartment Pitch	P	3.90	0.153	4.10	0.161
Sprocket Hole Diameter	P ₀	3.90	0.153	4.10	0.161
Centers Line Dimensions Length Direction	P ₂	1.95	0.076	2.05	0.080
Carrier Tape Thickness	t	—	—	0.30	0.012
Carrier Tape Width	W	7.70	0.303	8.30	0.326
Flange Diameter	A	178.0	7.008	180.0	7.087
Hub Spindle Hole	C	12.50	0.492	13.50	0.531
Hub Diameter	D ₂	70.00	2.755	72.00	2.830
Fixing Tape Width	W ₁	5.25	0.206	5.35	0.210
Flange Space Between Flanges	T	12.50	0.492	13.50	0.531
Compartment Length	A ₀	2.72	0.107	2.92	0.115
Compartment Width	B ₀	3.25	0.128	3.45	0.136

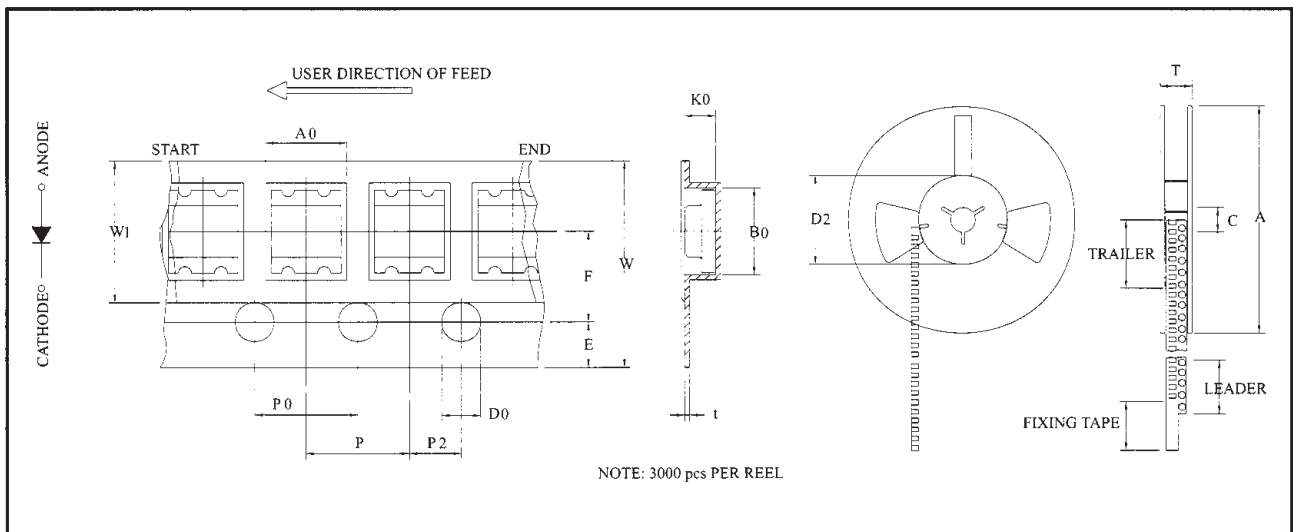



TAPE AND REEL SURFACE MOUNT CHIP LED LAMPS

- DEVICE NUMBER: VSM-15xx73-4B
- FEATURES:
 - Compatible with automatic placement equipment
 - Surface Mount assembly lamp
 - High efficiency low power consumption
 - Long life solid state reliability
- TAPPING AND PACKAGING SPECIFICATION

ITEM	SYMBOL	SPECIFICATION			
		Minimum		Maximum	
		mm	inch	mm	inch
Tape Feed Hole Diameter (DIA)	D ₀	1.40	0.055	1.60	0.063
Feed Hole Location	E	1.65	0.064	1.85	0.073
Centers Line Dimensions Length Direction	F	3.45	0.135	3.55	0.139
Compartment Depth	K ₀	1.20	0.047	1.40	0.055
Compartment Pitch	P	3.90	0.153	4.10	0.161
Sprocket Hole Diameter	P ₀	3.90	0.153	4.10	0.161
Centers Line Dimensions Length Direction	P ₂	1.95	0.076	2.05	0.080
Carrier Tape Thickness	t	—	—	0.30	0.012
Carrier Tape Width	W	7.70	0.303	8.30	0.326
Flange Diameter	A	178.0	7.008	180.0	7.087
Hub Spindle Hole	C	12.50	0.492	13.50	0.531
Hub Diameter	D ₂	70.00	2.755	72.00	2.830
Fixing Tape Width	W ₁	5.25	0.206	5.35	0.210
Flange Space Between Flanges	T	16.00	0.629	18.40	0.724
Compartment Length	A ₀	2.20	0.087	2.40	0.094
Compartment Width	B ₀	3.20	0.126	3.40	0.134

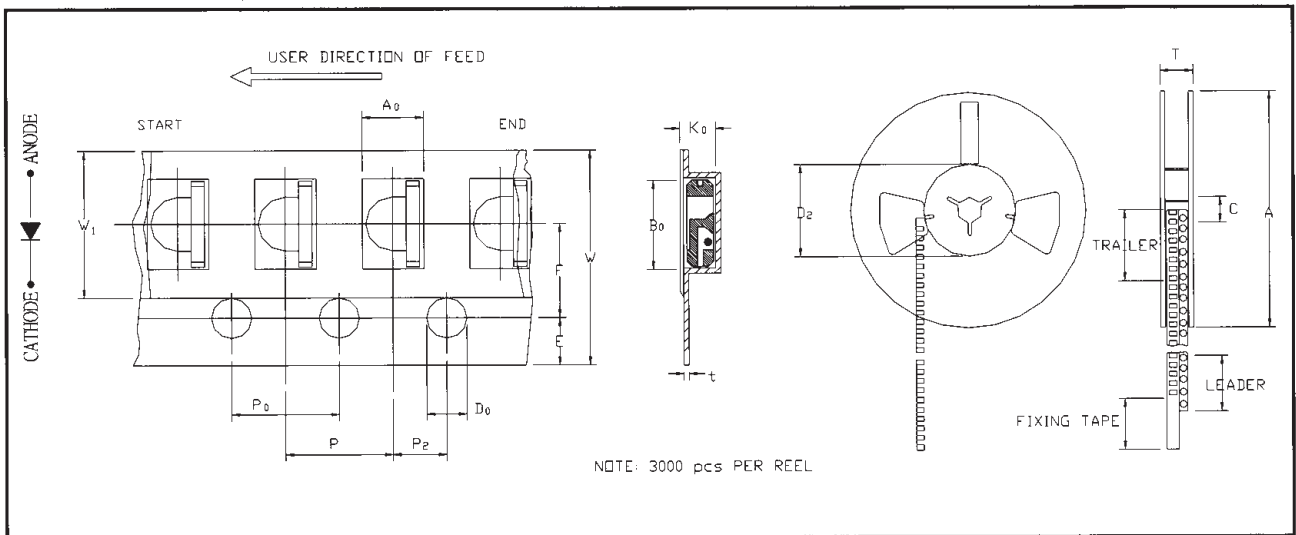



TAPE AND REEL SURFACE MOUNT CHIP LED LAMPS

- DEVICE NUMBER: VSM-10xx73-6H
- FEATURES:
 - Compatible with automatic placement equipment
 - Surface Mount assembly lamp
 - High efficiency low power consumption
 - Long life solid state reliability
- TAPPING AND PACKAGING SPECIFICATION

ITEM	SYMBOL	SPECIFICATION			
		Minimum		Maximum	
		mm	inch	mm	inch
Tape Feed Hole Diameter (DIA)	D ₀	1.40	0.055	1.60	0.063
Feed Hole Location	E	1.65	0.064	1.85	0.073
Centers Line Dimensions Length Direction	F	3.45	0.135	3.55	0.139
Compartment Depth	K ₀	0.45	0.018	0.55	0.054
Compartment Pitch	P	3.90	0.153	4.10	0.161
Sprocket Hole Diameter	P ₀	3.90	0.153	4.10	0.161
Centers Line Dimensions Length Direction	P ₂	1.95	0.076	2.05	0.080
Carrier Tape Thickness	t	—	—	0.30	0.012
Carrier Tape Width	W	7.70	0.303	8.30	0.326
Flange Diameter	A	178.0	7.008	180.0	7.087
Hub Spindle Hole	C	12.50	0.492	13.50	0.531
Hub Diameter	D ₂	70.00	2.755	72.00	2.830
Fixing Tape Width	W ₁	5.25	0.206	5.35	0.210
Flange Space Between Flanges	T	12.50	0.492	13.50	0.531
Compartment Length	A ₀	1.35	0.053	1.45	0.115
Compartment Width	B ₀	1.70	0.067	1.80	0.136

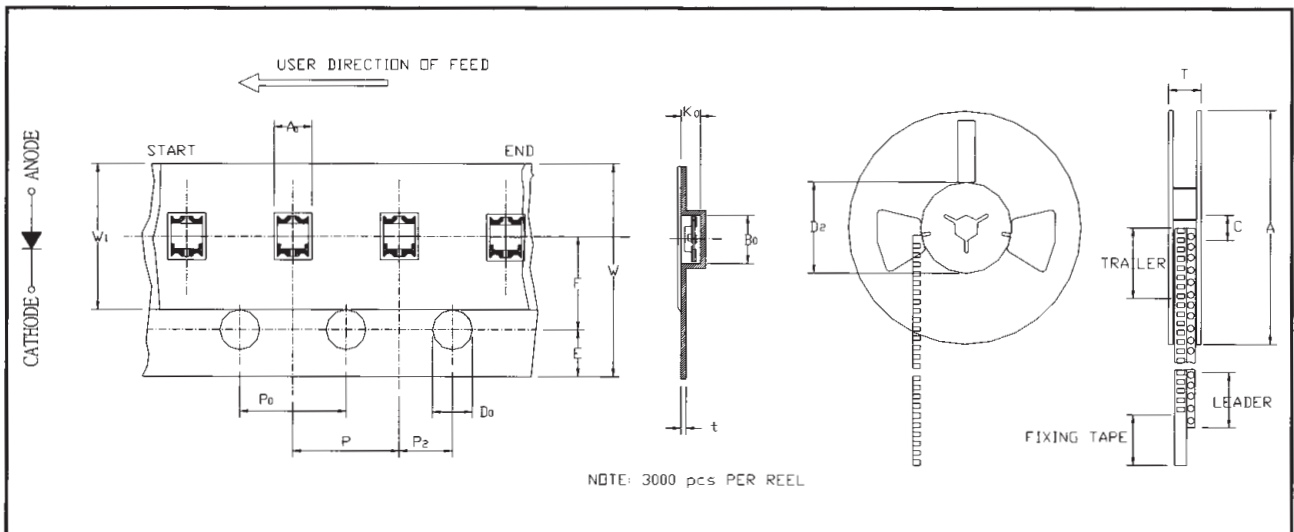



TAPE AND REEL SURFACE MOUNT CHIP LED LAMPS

- DEVICE NUMBER: VSM-10xxx73-3G
- FEATURES:
 - Compatible with automatic placement equipment
 - Surface Mount assembly lamp
 - High efficiency low power consumption
 - Long life solid state reliability
- TAPPING AND PACKAGING SPECIFICATION

ITEM	SYMBOL	SPECIFICATION			
		Minimum		Maximum	
		mm	inch	mm	inch
Tape Feed Hole Diameter (DIA)	D ₀	1.40	0.055	1.60	0.063
Feed Hole Location	E	1.65	0.064	1.85	0.073
Centers Line Dimensions Length Direction	F	3.45	0.135	3.55	0.139
Compartment Depth	K ₀	0.95	0.037	0.15	0.045
Compartment Pitch	P	3.90	0.153	4.10	0.161
Sprocket Hole Diameter	P ₀	3.90	0.153	4.10	0.161
Centers Line Dimensions Length Direction	P ₂	1.95	0.076	2.05	0.080
Carrier Tape Thickness	t	—	—	0.30	0.012
Carrier Tape Width	W	7.70	0.303	8.30	0.326
Flange Diameter	A	178.0	7.008	180.0	7.087
Hub Spindle Hole	C	12.50	0.492	13.50	0.531
Hub Diameter	D ₂	70.00	2.755	72.00	2.830
Fixing Tape Width	W ₁	5.25	0.206	5.35	0.210
Flange Space Between Flanges	T	12.50	0.492	13.50	0.531
Compartment Length	A ₀	2.55	0.100	2.75	0.108
Compartment Width	B ₀	2.55	0.100	2.75	0.108

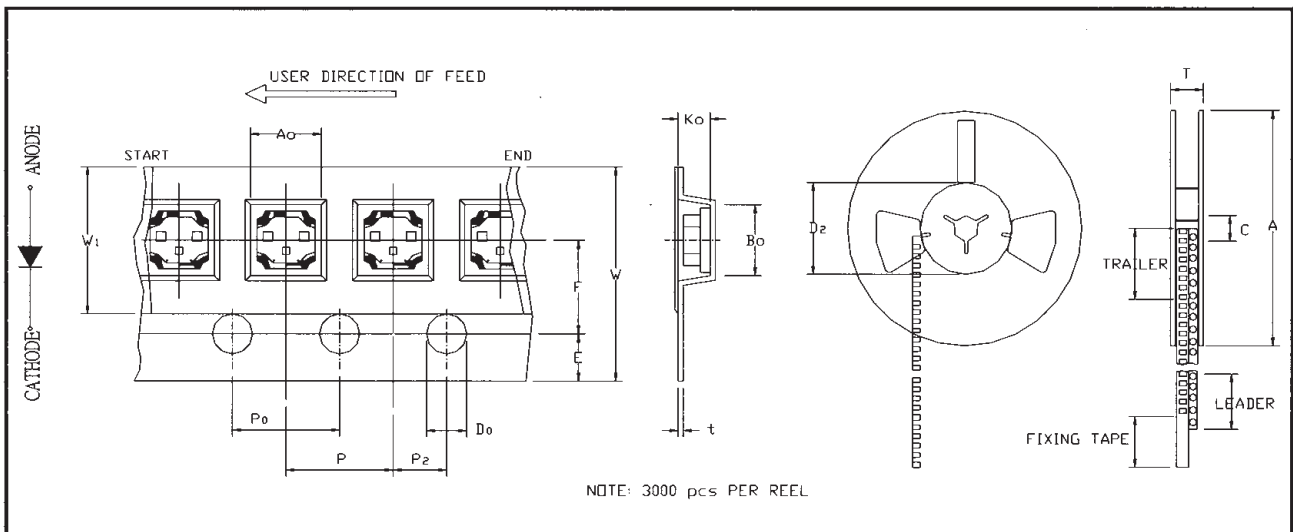



TAPE AND REEL SURFACE MOUNT CHIP LED LAMPS

- DEVICE NUMBER: VLL-10xxx73-6T
- FEATURES:
 - Compatible with automatic placement equipment
 - Surface Mount assembly lamp
 - High efficiency low power consumption
 - Long life solid state reliability
- TAPPING AND PACKAGING SPECIFICATION

ITEM	SYMBOL	SPECIFICATION			
		Minimum		Maximum	
		mm	inch	mm	inch
Tape Feed Hole Diameter (DIA)	D ₀	1.40	0.055	1.60	0.063
Feed Hole Location	E	1.65	0.064	1.85	0.073
Centers Line Dimensions Length Direction	F	3.45	0.135	3.55	0.139
Compartment Depth	K ₀	0.60	0.022	0.80	0.031
Compartment Pitch	P	3.90	0.153	4.10	0.161
Sprocket Hole Diameter	P ₀	3.90	0.153	4.10	0.161
Centers Line Dimensions Length Direction	P ₂	1.95	0.076	2.05	0.080
Carrier Tape Thickness	t	---	---	0.30	0.012
Carrier Tape Width	W	7.70	0.303	8.30	0.326
Flange Diameter	A	178.0	7.008	180.0	7.087
Hub Spindle Hole	C	12.50	0.492	13.50	0.531
Hub Diameter	D ₂	70.00	2.755	72.00	2.830
Fixing Tape Width	W ₁	5.25	0.206	5.35	0.210
Flange Space Between Flanges	T	12.50	0.492	13.50	0.531
Compartment Length	A ₀	1.63	0.064	1.83	0.072
Compartment Width	B ₀	1.65	0.065	1.85	0.073

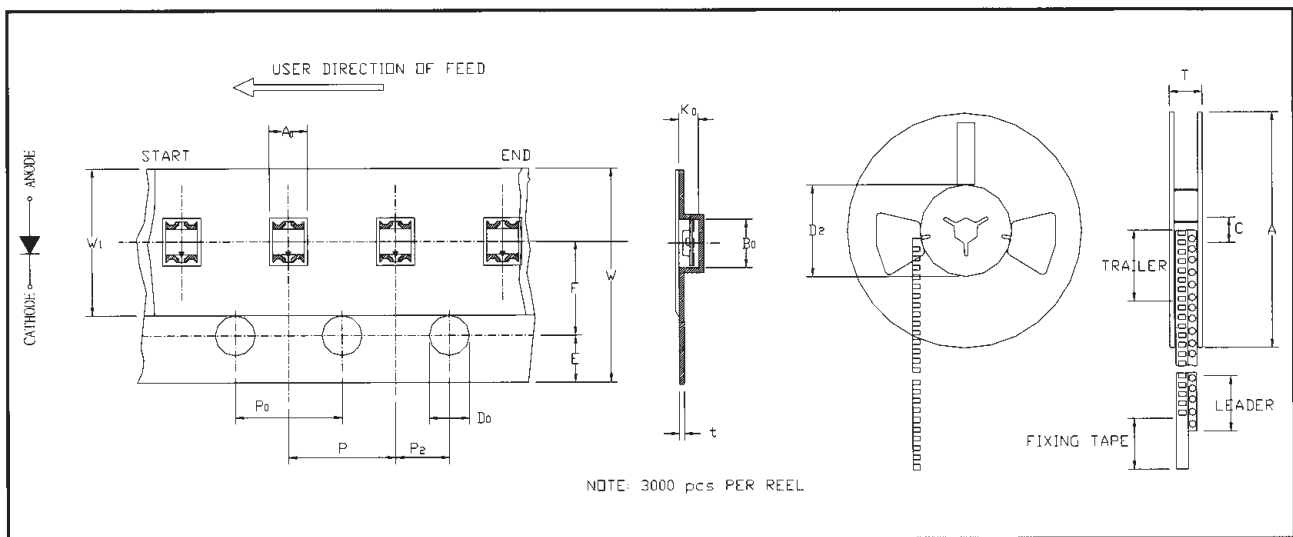



TAPE AND REEL AXIAL LED LAMPS WITH "GULL WING" LAMPS

- DEVICE NUMBER: VLL-17x03-F7
- FEATURES:
 - Compatible with automatic placement equipment
 - Surface Mount assembly lamp
 - High efficiency low power consumption
 - Long life solid state reliability
- TAPPING AND PACKAGING SPECIFICATION

ITEM	SYMBOL	SPECIFICATION			
		Minimum		Maximum	
		mm	inch	mm	inch
Tape Feed Hole Diameter (DIA)	D_0	1.40	0.055	1.55	0.061
Feed Hole Location	E	1.65	0.065	1.85	0.072
Centers Line Dimensions Length Direction	F	5.45	0.215	5.55	0.218
Compartment Depth	K_0	3.10	0.122	3.30	0.130
Carrier Tape Overall Thickness	K	—	—	2.40	0.094
Compartment Pitch	P	3.90	0.153	4.10	0.161
Sprocket Hole Diameter	P_0	3.90	0.153	4.10	0.161
Centers Line Dimensions Length Direction	P_2	1.95	0.076	2.05	0.080
Carrier Tape Thickness	t	—	—	0.30	0.012
Carrier Tape Width	W	12.00	0.472	12.30	0.484
Flange Diameter	A	178.0	7.008	180.0	7.087
Hub Spindle Hole	C	12.50	0.492	13.50	0.531
Hub Diameter	D_2	20.00	0.788	21.50	0.846
Fixing Tape Width	W_1	9.00	0.354	9.30	0.366
Flange Space Between Flanges	T	16.00	0.629	18.40	0.724
Compartment Length	A_0	2.20	0.087	2.40	0.094
Compartment Width	B_0	3.90	0.154	4.10	0.161

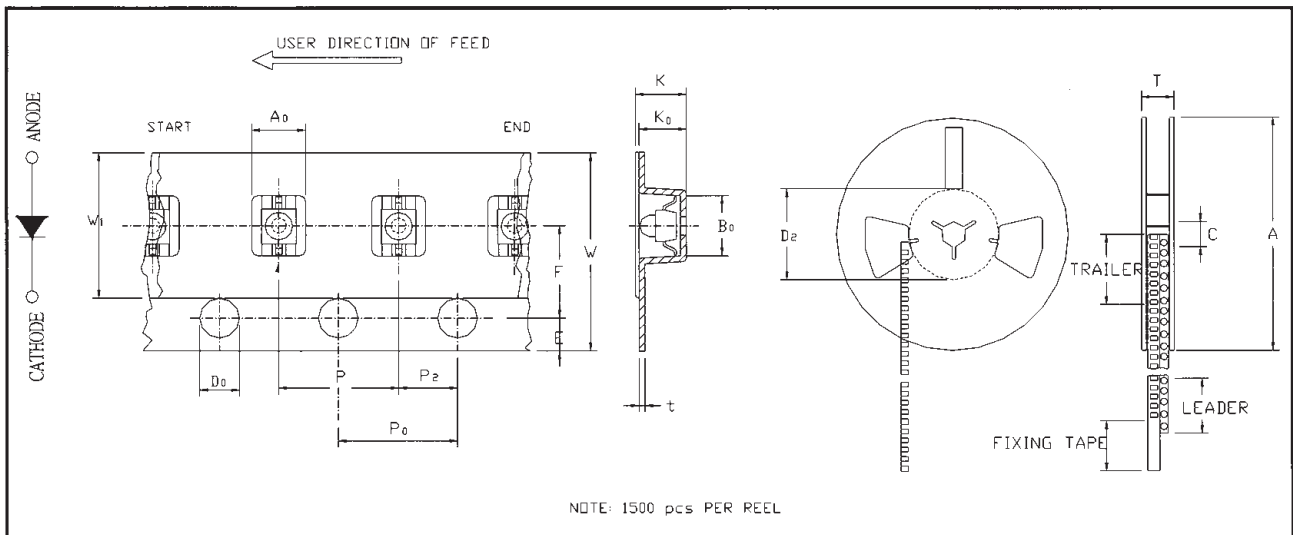



TAPE AND REEL AXIAL LED LAMPS WITH "YOKE" LEAD

- DEVICE NUMBER: VLL-17x03-F8
- FEATURES:
 - Compatible with automatic placement equipment
 - Surface Mount assembly lamp
 - High efficiency low power consumption
 - Long life solid state reliability
- TAPPING AND PACKAGING SPECIFICATION

ITEM	SYMBOL	SPECIFICATION			
		Minimum		Maximum	
		mm	inch	mm	inch
Tape Feed Hole Diameter (DIA)	D ₀	1.40	0.055	1.55	0.061
Feed Hole Location	E	1.65	0.065	1.85	0.072
Centers Line Dimensions Length Direction	F	5.45	0.215	5.55	0.218
Compartment Depth	K ₀	3.02	0.119	3.22	0.127
Compartment Pitch	P	3.90	0.153	4.10	0.161
Sprocket Hole Diameter	P ₀	3.90	0.153	4.10	0.161
Centers Line Dimensions Length Direction	P ₂	1.95	0.076	2.05	0.080
Carrier Tape Thickness	t	—	—	0.30	0.012
Carrier Tape Width	W	12.00	0.472	12.30	0.484
Flange Diameter	A	178.0	7.008	180.0	7.087
Hub Spindle Hole	C	12.50	0.492	13.50	0.531
Hub Diameter	D ₂	20.00	0.788	21.50	0.846
Fixing Tape Width	W ₁	9.00	0.354	9.30	0.366
Flange Space Between Flanges	T	16.00	0.629	18.40	0.724
Compartment Length	A ₀	2.29	0.090	2.49	0.098
Compartment Width	B ₀	7.62	0.300	7.82	0.308

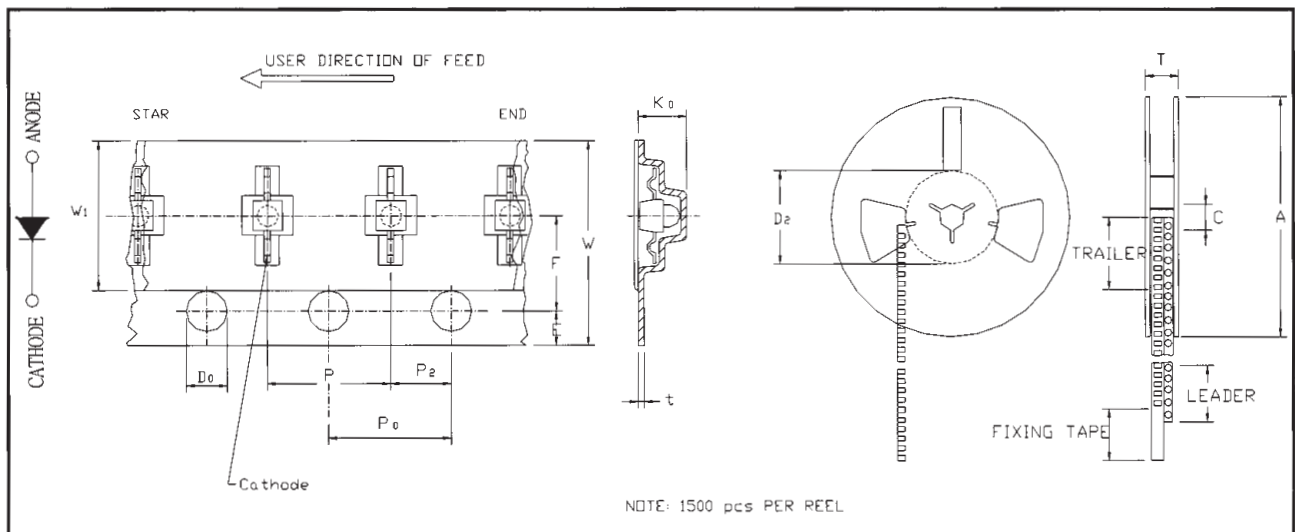



TAPE AND REEL AXIAL LED LAMPS WITH "Z" BENT LEAD

- DEVICE NUMBER: VLL-17x03-F9
- FEATURES:
 - Compatible with automatic placement equipment
 - Surface Mount assembly lamp
 - High efficiency low power consumption
 - Long life solid state reliability
- TAPPING AND PACKAGING SPECIFICATION

ITEM	SYMBOL	SPECIFICATION			
		Minimum		Maximum	
		mm	inch	mm	inch
Tape Feed Hole Diameter (DIA)	D ₀	1.40	0.055	1.55	0.061
Feed Hole Location	E	1.65	0.065	1.85	0.072
Centers Line Dimensions Length Direction	F	5.45	0.215	5.55	0.218
Compartment Depth	K ₀	3.00	0.118	3.20	0.126
Compartment Pitch	P	3.90	0.153	4.10	0.161
Sprocket Hole Diameter	P ₀	3.90	0.153	4.10	0.161
Centers Line Dimensions Length Direction	P ₂	1.95	0.076	2.05	0.080
Carrier Tape Thickness	t	—	—	0.30	0.012
Carrier Tape Width	W	12.00	0.472	12.30	0.484
Flange Diameter	A	178.0	7.008	180.0	7.087
Hub Spindle Hole	C	12.50	0.492	13.50	0.531
Hub Diameter	D ₂	20.00	0.788	21.50	0.846
Fixing Tape Width	W ₁	9.00	0.354	9.30	0.366
Flange Space Between Flanges	T	16.00	0.629	18.40	0.724
Compartment Length	A ₀	1.87	0.074	2.07	0.081
Compartment Width	B ₀	6.30	0.248	6.50	0.256

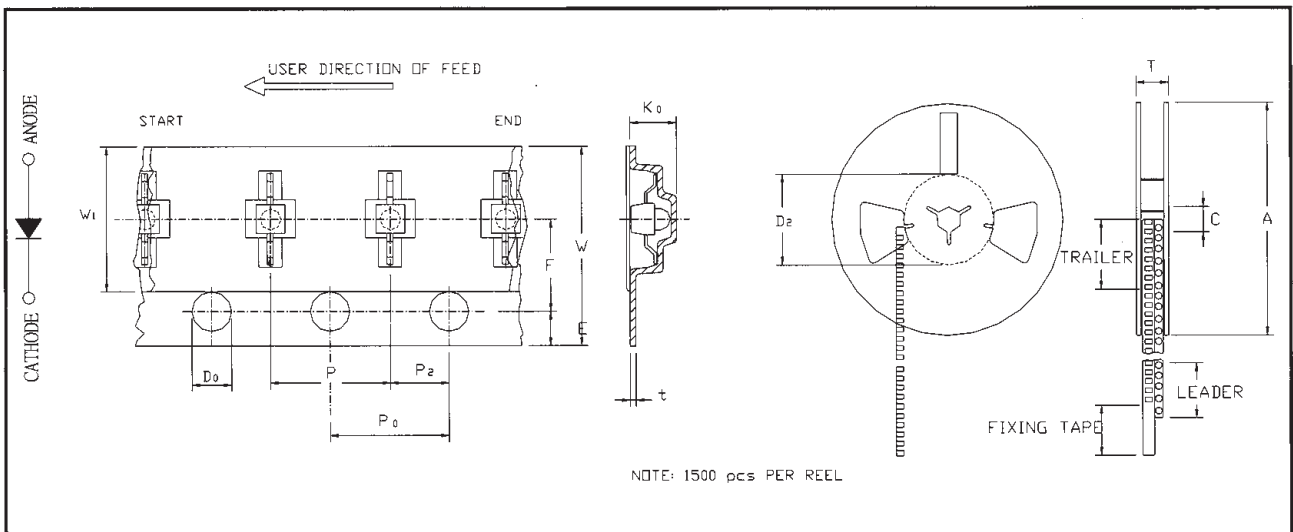



SELECTION GUIDE (PART NO SYSTEM)

(1) VXX - (2) XX (3) XXX (4) X (5) X - (6) XX

VINCENC HOME DEVELOPMENT CO., LTD.

- (1) PRODUCT TYPE → SM : Surface Mount Device
LL : LED Lamp
- (2) SIZE
- (3) EMITTING COLOR
- (4) LEAD FRAM
- (5) LENS APPEARANCE
- (6) LAMP CATEGORY

- (2) SIZE :
 - 1210/ 1206/ 1204 : 15xxx series
 - 0802 : 11xxx series 0805 : 12xxx series 0603 : 10xxx series
- (3) EMITTING COLOR :
 - A : GaAs/GaAs 940nm A1 : GaAsAl/GaAs 940nm B : GaAlAs 880nm B1 / B2 : GaAlAs/GaAlAs 850nm C / C2 : 940nm
- (4) LEAD FRAM :
 - 7 : SMD TYPE 0 : AXIAL
- (5) LENS APPEARANCE :
 - 1 : Color Diffused 2 : Color Transparent 3 : Water Clear 4: White Diffused
- (6) LAMP CATEGORY :
 - IE : Infrared Emitting Diode PT : Phototransistors PD : Photodiodes

TYPICAL ELECTIEICAL-OPTICAL CHARACTERISTICS CURVES

Infrared Emitting Diodes Series :

Fig.3 FORWARD CURRENT VS. FORWARD VOLTAGE

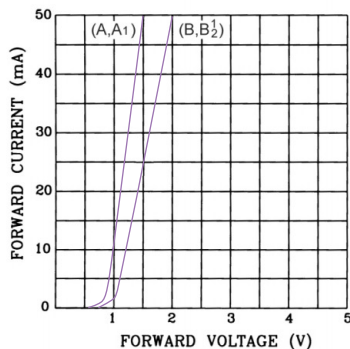

Fig.4 RELATIVE LUMINOUS INTENSITY VS. AMBIENT TEMPERATURE

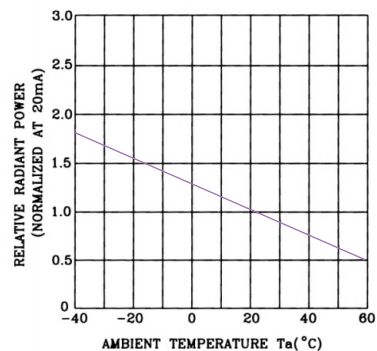

Fig.5 RELATIVE LUMINOUS INTENSITY VS. FORWARD CURRENT

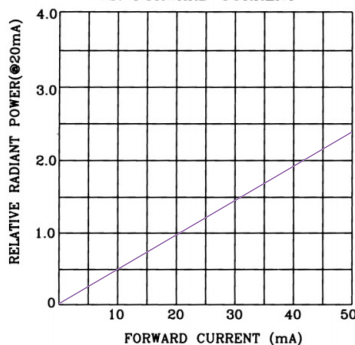
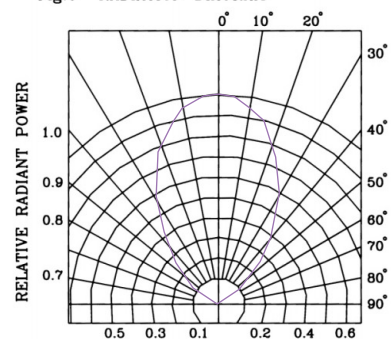

Fig.6 RADIATION DIAGRAM



SELECTION GUIDE TO INFRARED SERIES

TYPICAL ELECTIEICAL-OPTICAL CHARACTERISTICS CURVES

Photo transistors Series:

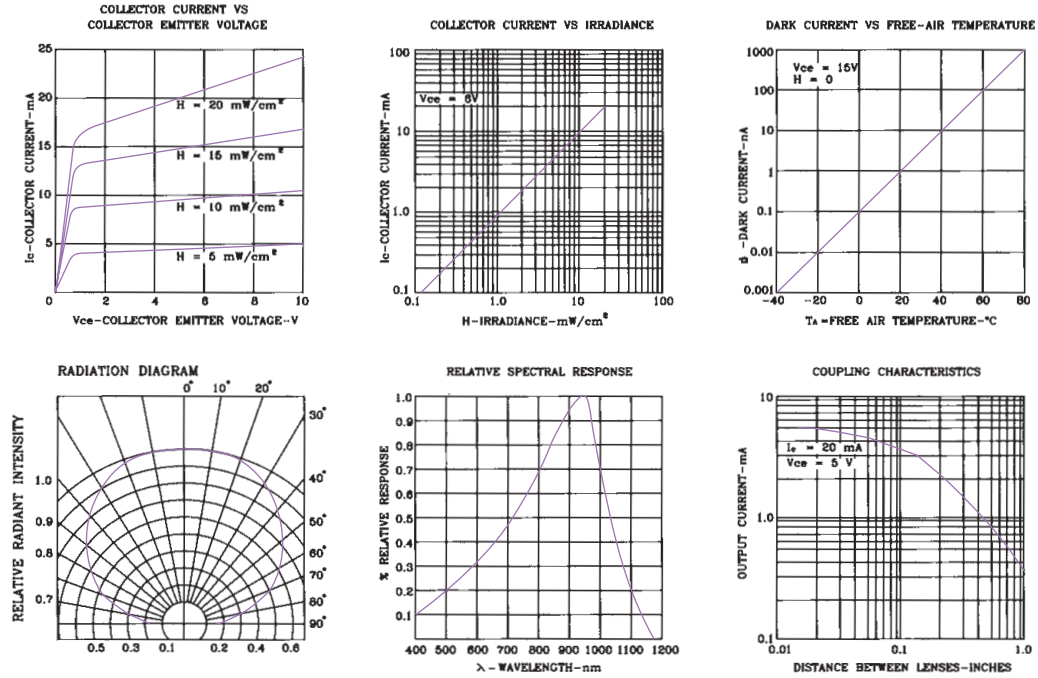

TYPICAL ELECTIEICAL-OPTICAL CHARACTERISTICS CURVES

Photo diodes Series:

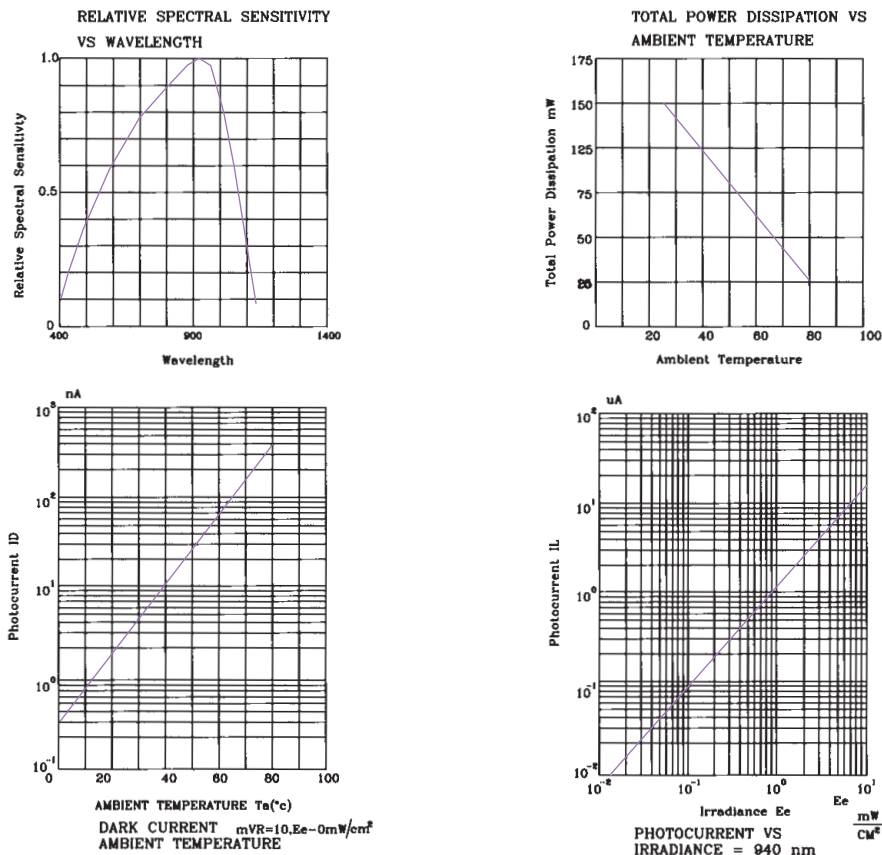

SURFACE MOUNT INFRARED EMITTING DIODES

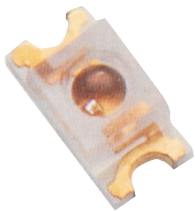

SM-15Xx73-IE Series

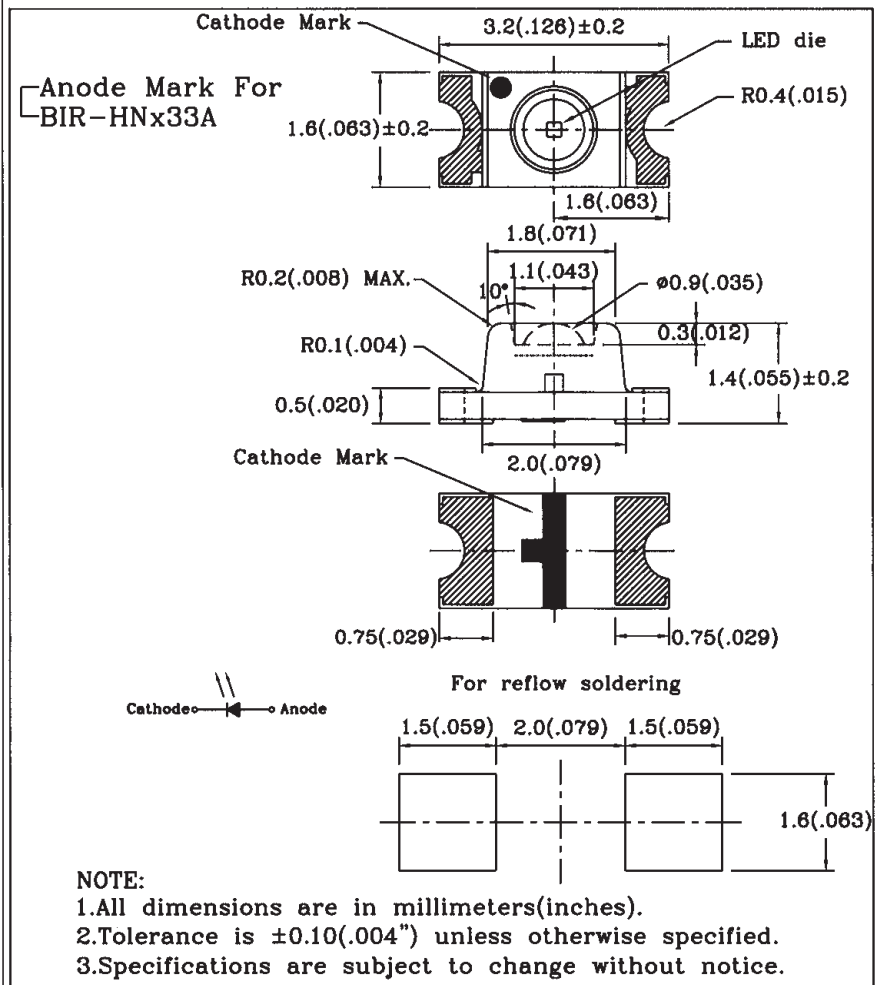

Absolute Maximum Ratings(Ta=25°C)

	UNIT	SPEC.
IF	mA	30
IFP	A	1.0
VR	V	5
Topr	°C	-25~+80
Tstg	°C	-30~+85

Part No.	Chip			Lens Appearance	Electro-Optical Data(At 20mA)					Ifp=20mA PW=10us DC=1%		Viewing Angle 2θ 1/2 (deg)
	Material	λ p (nm)	Δ λ (nm)		Vf(V)		Ir (uA)	Radiant Power Po (mw/sr)		Tr (ns)	Tf (ns)	
					Typ.	Max.		Min.	Typ.			
VSM-15A73-IE	GaAs	940	50	Water Clear	1.2	1.7	50	0.71	2.00	500	200	70°
VSM-15A173-IE	GaAlAs	940	50		1.2	1.7	50	1.00	4.00	500	200	
VSM-15B73-IE	GaAlAs	880	50		1.4	2.0	50	0.71	1.20	500	200	
VSM-15B173-IE	GaAlAs	850	50		1.4	2.0	50	1.98	4.00	500	200	
VSM-15B273-IE	GaAlAs	850	50		1.4	2.0	50	1.41	3.00	500	200	

SURFACE MOUNT PHOTO TRANSISTORS

SM-15A73-PTX Series

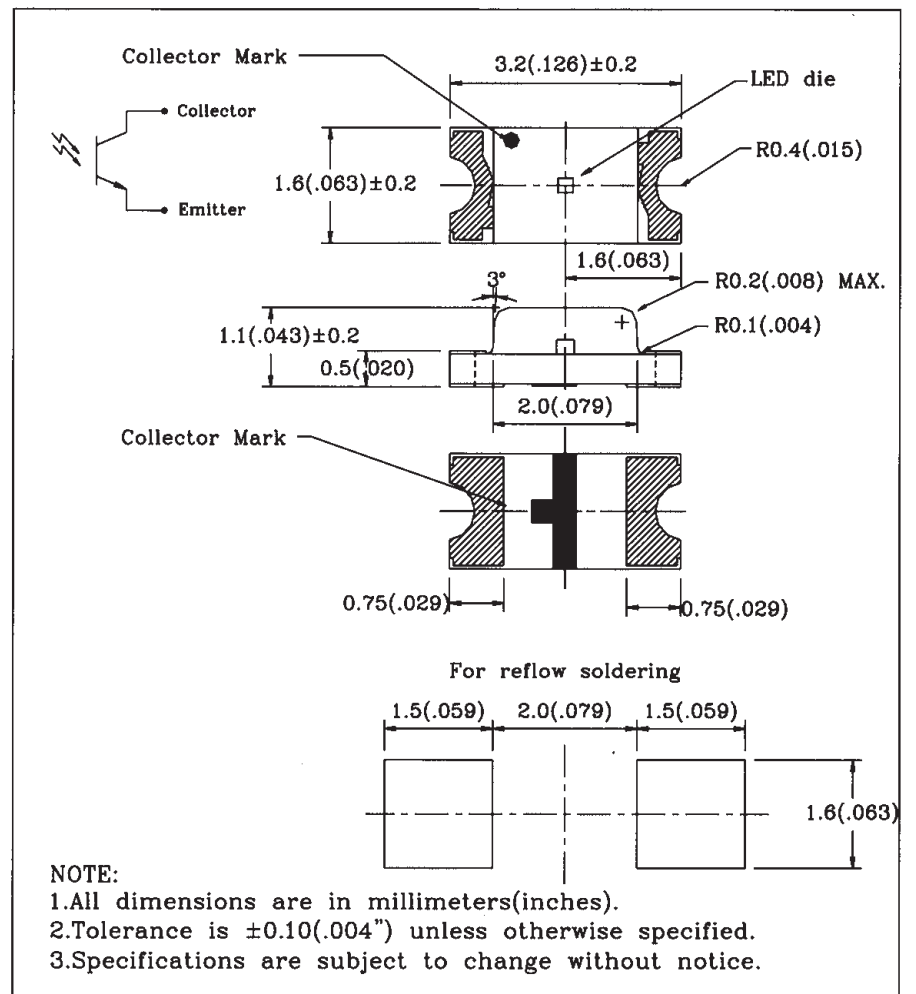
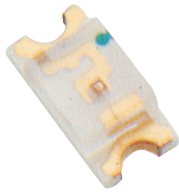

Absolute Maximum Ratings(Ta=25°C)

	UNIT	SPEC.
Collector-Emitter Saturation Voltage Vce(sat)	V	0.5 Ic=100uA
Emitter-Collector Breakdown Voltage Bveco	V	5.0 Ic=100uA
Topr	°C	-25~+80
Tstg	°C	-30~+85
Power Dissipation	mW	100

Part No.	Parameter						
	Spectrum Sensitivity	Peak Wavelength	Collector Light Current Vce=5V, H=1.0mw/cm ²		Collector Dark Current Vce=20V, H=1.0mw/cm ²	Rise/Fall Time Vce=5V, Ic=1mA RL=1KΩ	Viewing Angle 2θ 1/2 (deg)
	λ (nm)	λp (nm)	Ic(ON) (mA)	IcEO (nA)	TR/TF (us)		
			Min.	Typ.	Max.	Typ.	
VSM-15A73-PT	500-1000	940	0.67	1.50	100	15/15	140°
VSM-15A73-PT1	500-1000	940	2.00	3.00	100	15/15	
VSM-15A73-PT3	500-1000	940	2.00	4.00	100	15/15	
VSM-15A73-PT8	500-1000	940	2.00	5.00	100	15/15	

SURFACE MOUNT PHOTO DIODES

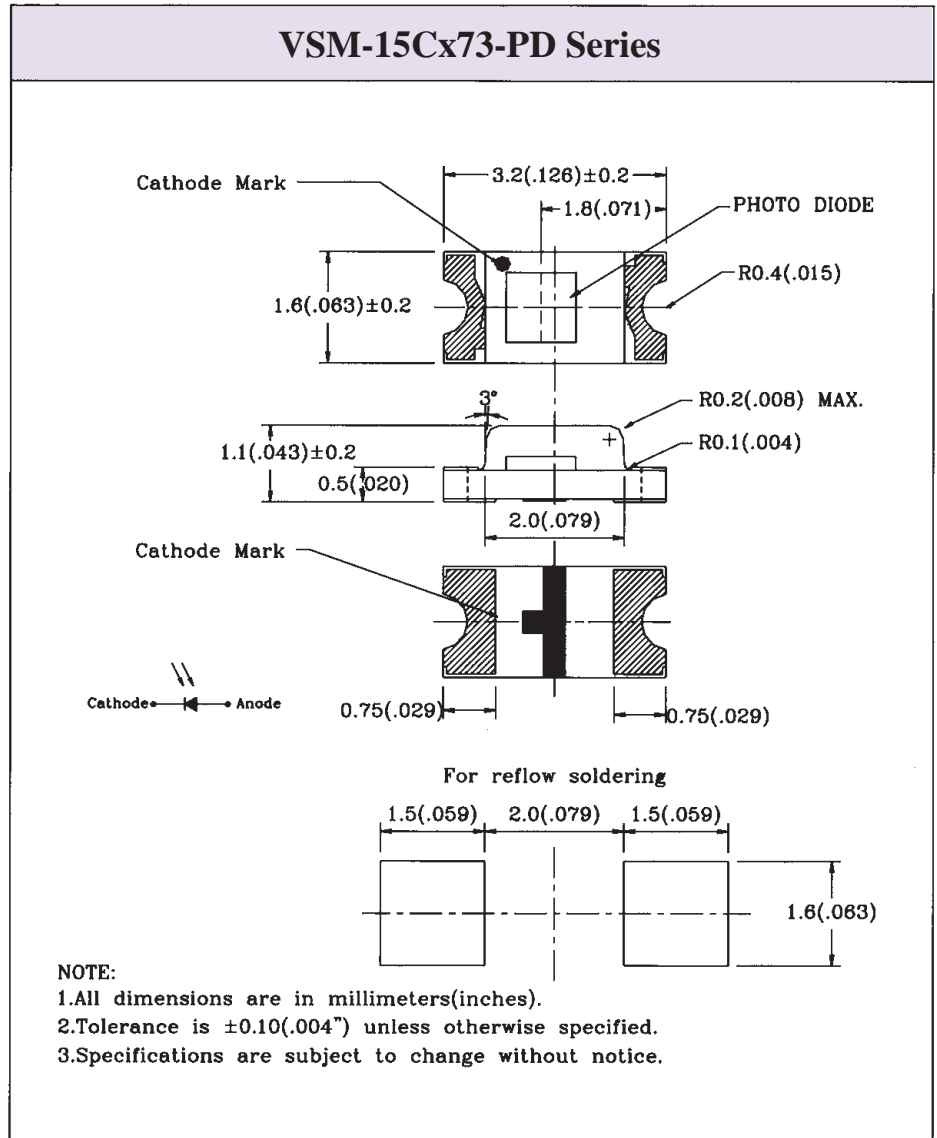
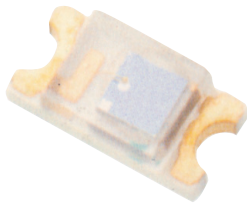

Absolute Maximum Ratings(Ta=25°C)

	UNIT	SPEC.
Topr	°C	-25~+80
Tstg	°C	-30~+85

Part No.	Open Circuit Voltage	Short Circuit Current	Reverse Dark Current	Reverse Light Current	Reverse Break Down Voltage	Rise/Fall Time	Peak Wave Length	Viewing Angle 2θ 1/2 (deg)
	V _{OC} H=5.0mw/cm ² Typ. (mV)	I _{SC} H=5.0mw/cm ² Typ. (uA)	I _{D(R)} V _R =10V H=0mw/cm ² Max. (nA.)	I _L V _R =5.0V H=5.0mw/cm ² Typ. (uA)	V _{BR} I _R =100uA H=0mw/cm ² Min. (V)	T _R /T _F V _R =10V R _L =1KΩ (ns)	λ _p (nm)	
VSM-15C73-PD	450	2.0	10	2.0	30	6/6	940	140°
VSM-15C173-PD	550	7.0	10	5.0	30	10/10	940	